

Mario Andres Bonilla-Vallejo

Magister Scientiae, Estudiante de doctorado, Instituto de Arquitectura y Urbanismo
Universidade de Sao Paulo
Sao Paulo, Brasil
<https://orcid.org/0000-0002-8817-929X>
mariovallejo@usp.br

Marcelo Tramontano

Doctor en en Arquitectura y Urbanismo. Profesor Asociado, Instituto de Arquitectura y Urbanismo
Universidade de Sao Paulo
Sao Paulo, Brasil
<https://orcid.org/0000-0002-0044-4432>
tramont@sc.usp.br

ARTICULATION OF DESIGN PROCESSES, COMPUTING, CYBERNETICS, AND BIM: A RETROSPECTIVE

ARTICULACIÓN DE PROCESOS DE DISEÑO, COMPUTACIÓN, CIBERNÉTICA Y BIM: UNA RETROSPECTIVA

ARTICULAÇÃO DE PROCESSOS DE PROJETO, COMPUTAÇÃO, CIBERNÉTICA E BIM: UMA RETROSPECTIVA



Figura 0. Software URBAN5.
Fuente: Adaptado de Negroponete, 1970.

Artículo financiado por CAPES a través del PROEX (Programa de Excelência Acadêmica) código 88887.817168/2023-00.

RESUMEN

El artículo explora el desarrollo histórico y teórico del *Building Information Modeling* (BIM) y de los procesos de diseño que este conlleva. El estudio deriva de una investigación de doctorado y tiene como objetivo construir una comprensión ampliada del proceso de informatización del pensamiento arquitectónico que condujo al BIM, considerando aportes del campo de la Cibernética y de las Ciencias de la Computación. Se profundiza en el contexto histórico del siglo XX y se destacan los avances paralelos e interdependientes en la Arquitectura, la Cibernética y la Computación. Basado en una revisión bibliográfica, análisis retrospectivo y teórico, el artículo hace hincapié en las contribuciones de trabajos que sistematizaron procesos de diseño e introdujeron abordajes metodológicos sistémicos que valoran la declaración y estructuración de las informaciones de diseño y que también contribuyeron tanto para la incorporación de la computación en los procesos de diseño, como para su desarrollo. El texto presenta las contribuciones de instituciones de investigación del Reino Unido y Estados Unidos en el desarrollo de bases computacionales para la arquitectura, recalando que la diversidad geográfica de los avances en el campo va más allá de estos dos ejes. Tales programas computacionales, influenciados por las teorías cibernéticas, se centraron en crear modelos y sistemas para la descripción de la información, siendo cruciales para el avance del BIM. Por fin, se señala la importancia de la traducción del pensamiento arquitectónico en información estructurada para ser procesado por bases computacionales, incluyendo aquellas de base BIM. Se concluye reforzando que, aunque el BIM y los actuales procesos de diseño informatizados provengan de un amplio contexto histórico y geopolítico del siglo XX, involucrando investigaciones teóricas, militares y profesionales, su desarrollo fue guiado para asistir la producción de modelos de arquitectura norte-atlánticos.

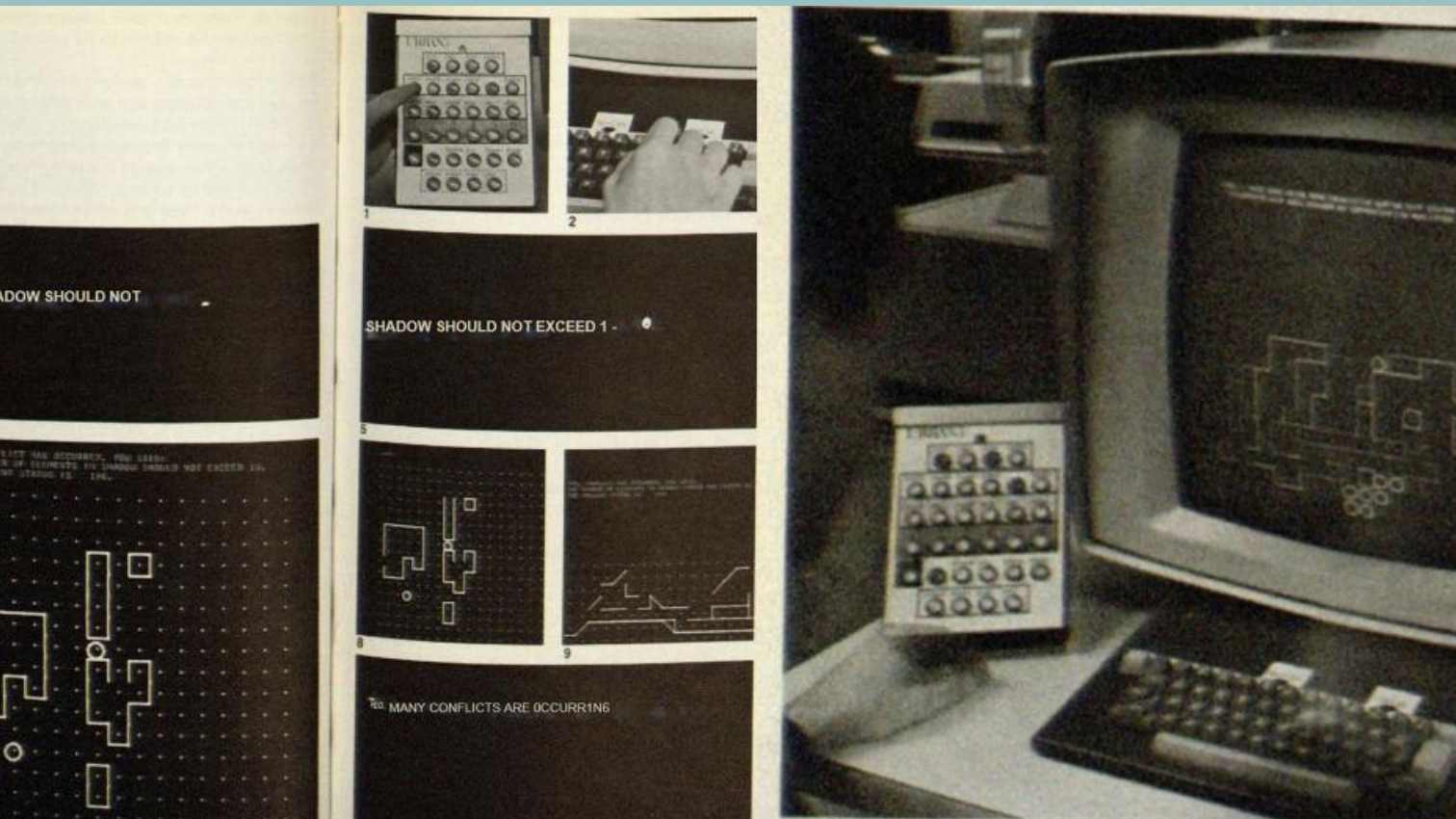
Palabras clave: cibernética, diseño arquitectónico, diseño digital, historia, informatización

ABSTRACT

This article explores the historical and theoretical developments of Building Information Modeling (BIM) and the associated design processes. The study stems from ongoing doctoral research and aims to build an expanded understanding of the informatization process of architectural thought that led to BIM, considering contributions from the Cybernetics and Computing fields. The paper looks into the historical context of the 20th century and highlights the parallel and interdependent developments in Architecture, Cybernetics, and Computer Science. Based on a bibliographic review, retrospective, and theoretical analysis, this article emphasizes the contributions of works that systematized design processes and introduced systemic methodological approaches. Those works acknowledge the value of declaration and structuring of design information and contribute to incorporating computing into design processes and their development. The work presents the contributions of research institutions from the United Kingdom and the United States in developing computer programs for architecture, emphasizing that the geographical diversity of advancements in the field goes beyond these two lines. These computer programs were influenced by cybernetic theories, which were crucial for BIM development, and were created to produce models and systems to describe information. Finally, the importance of translating architectural thought into structured data that might be processable through computer programs, including BIM software, is highlighted, concluding that although BIM and developments of the current digital design processes followed the goal of assisting the production of North Atlantic architectural models, they originated from a broad and diverse historical and geopolitical context of the 20th century, involving theoretical, military, and professional research

Keywords: cybernetics, architecture design, digital design, history, informatization

RESUMO

O artigo explora o desenvolvimento histórico e teórico do *Building Information Modelling* (BIM) e dos processos de projeto envolvidos. O estudo deriva de uma pesquisa de doutorado e tem como objetivo construir uma compreensão ampliada do processo de informatização do pensamento arquitetônico que levou ao BIM, considerando as contribuições do campo da cibernética e da ciência da computação. Ele se aprofunda no contexto histórico do século XX e destaca os desenvolvimentos paralelos e interdependentes da arquitetura, da cibernética e da ciência da computação. Com base em uma revisão da literatura, análise retrospectiva e teórica, o artigo enfatiza as contribuições de trabalhos que sistematizaram os processos de projeto e introduziram abordagens metodológicas sistêmicas que valorizam a declaração e a estruturação das informações de projeto e que também contribuíram para a incorporação da computação nos processos de projeto e seu desenvolvimento. O texto apresenta as contribuições das instituições de pesquisa do Reino Unido e dos EUA para o desenvolvimento de fundamentos computacionais para a arquitetura, enfatizando que a diversidade geográfica dos avanços no campo vai além desses dois eixos. Esses softwares, influenciados por teorias cibernéticas, concentraram-se na criação de modelos e sistemas para a descrição de informações, sendo cruciais para o avanço do BIM. Por fim, aponta-se a importância de traduzir o pensamento arquitetônico em informações estruturadas a serem processadas por bases computacionais, inclusive as baseadas em BIM. Conclui-se reforçando que, embora o BIM e os atuais processos de projeto baseados em computador tenham origem em um amplo contexto histórico e geopolítico do século XX, envolvendo pesquisas teóricas, militares e profissionais, seu desenvolvimento foi orientado para auxiliar a produção de modelos arquitetônicos norte-atlânticos.

Palavras-chave: cibernética, projeto arquitetônico, projeto digital, história, informatização

INTRODUCTION

1 First-order Cybernetics deals with studying a system's principles of organization, control, and communication without focusing on the system's constitution or functioning (Wiener, 1948).

2 Second-order Cybernetics consists of the study of systems under observation. It considers the observer part of the observed system and admits their interference in the organization of the parts (Foerster, 1974).

3 Conversation Theory explores the dynamics of interaction and learning through conversations, emphasizing the causal circular processes based on the feedback inherent in these interactions (Pask, 1976).

4 The General Theory of Systems studies the relationships between the parts and between the whole and the parts that compose it (Bertalanffy, 1976). The Austrian biologist Ludwig von Bertalanffy developed his ideas starting in the 1930s, publishing the first article on the subject in 1948 and the first edition of the General Systems Theory in 1968.

5 The Mathematical Theory of Communication focuses on transmitting messages with the least information loss, considering the noise in the transmission channel (Shannon, 1948).

6 Complexity Theory is a multidimensional and integrative non-reductionist approach that recognizes planetary complexity, uncertainty, and the condition of social reality's interdependence (Morin, 1977; 2011). The French anthropologist, sociologist, and philosopher Edgar Morin published the first book on the subject in 1977. It is based, among other postulates and fields of study, on cybernetic and systemic principles.

To understand the computerization of architectural thinking that led to the formulation and development of *Building Information Modeling* (BIM) and the design processes that this entails, the scenario of parallels and interdependencies of the 20th century's theoretical, computational, and architectural design process advances must be understood. The architectural thought referred to is structured under design methodologies that involve specific routines and dynamics of declaration and use of design information affiliated with the visions of architects such as Christopher Alexander (1965; 1977), Lucian Kroll (1994), Nicolaas John Habraken (1961; 1996), Yona Friedman (1971; 1973), Charles Eastman (1972) or groups and movements such as Archigram (Sadler, 2005) and Metabolists (Frampton, 2003; Rocha, [n.d.]), who systematized design processes, through research and experiments. In addition, they introduced systemic approaches that value the organization and structuring of design information, exploring the idea of open and flexible systems that allow the adaptation and continuous evolution of architectural designs.

Dubberly and Pangaro (2015) carefully crossed the paths of cybernetics, computing, counterculture, and design, identifying and illustrating a broad fabric of articulations and interdependencies. Although the reflection proposed here is developed similarly to that of Dubberly and Pangaro (2015), this work examined the articulated paths of Cybernetics with the advances in architectural design and Computing Processes. This aims at building a complex understanding—in terms of Morin (2011)—of the computerization of architectural thinking that led to the formulation and development of BIM and the design processes that it presupposes. For this, adopting a retrospective approach, a bibliographic review, historical rescue, and theoretical analysis were carried out, mainly through the dialog with postulates of First Order Cybernetics (Wiener, 1948) **1**; Second Order Cybernetics (Von Foerster, 1974) **2**; Conversation Theory (Pask, 1976) **3**; the General Systems Theory (Von Bertalanffy, 1976) **4**; the Mathematical Theory of Communication (Shannon, 1948) **5**; and Morin's Complex Thinking (1977; 2011) **6**. The retrospective approach involves analyzing past events, documents, and figures to address contemporary challenges and gain a more profound and expanded understanding of historical contexts. This approach is complex and incorporates several fields of study and research techniques (Bourke & Skinner, 2022), and coincides with the vision of Morin (1977), who advocates a dialogical and dialectical method that recognizes the complexity and interconnection of historical phenomena.

The understanding of design processes in BIM, to which reference is made and which guides the reflection, simultaneously refers to a technological structure of informatics, a set of specific design and production processes, and a methodology and procedures of management and access to information (Pita, 2021; Pita & Tramontano, 2023; Dounas et al., 2020). It is an understanding that allows one to interpret BIM's capacity to complexify the design processes, dealing with

sets of layers of interdependent information of diverse natures and enabling responsiveness and feedback between metadata and design parameters, between designer and design, in a constantly produced flow of information. It is argued that to achieve these dynamics of informational flows in the production of architecture, it was necessary to construct an extensive fabric of articulations that computerized architectural thinking, mainly with cybernetics (Quin, 2019), in a process that remains in force and that, without it, architecture could not be processed through BIM. It is pertinent to emphasize that, although it is important, the objective of this article does not lie in the discussion of current practices of design processes or the use of BIM, but rather in examining the historical and theoretical background that contributed to its formulation and development over the last century.

In addition to the introductory and concluding sections, this article is structured around two main sections. Starting with “The emergence of Architecture-oriented computer bases”, the genesis of the development of computer bases in Architecture is discussed, considering socio-political contexts and theoretical contributions from Cybernetics. Then, in the section “Cybernetics and Design processes”, the relationship between both fields of study is explored, examining how cybernetic and computational principles were applied and incorporated into the design process and how that node of connections contributed to the computerization of architectural thinking.

The emergence of architecture-oriented computer bases

Douglas Engelbart (1962), aligned with the premises of Ashby's work (1956), presented the concept of augmented intelligence in a network, proposing a design process assisted by a computational system, the **Clerk**. In the opening pages of his report, prepared for the Air Force Office of Scientific Research, Engelbart points out:

Ignoring the representation on the screen, the architect begins to insert a series of specifications and data about a six-inch slab, twelve-inch concrete walls, [...] the revised scene will appear on the screen, the structure is taking shape. They examine, adjust, take information from the clerk's catalog, and readjust. [...] they use the lists of specifications of the “clerk” to modify them or add others. They grow in an increasingly detailed and interconnected structure, representing the mature thinking that led to the design. (Engelbart, 1962, p. 5)

In addition to his cybernetic understanding applied to the design process, Engelbart (1962) described with significant precision those that, years later, would be design-oriented experimental systems. This was a vision of an architect of the future who, according to Ashby (1956), would expand his intelligence with the assistance of computing. It was also the vision of a design process based on interdependent data banks that directly relate to a symbol system supporting human-machine interaction. In 1959, the **Computer Applications Group** and the Design Division of the MIT Department of

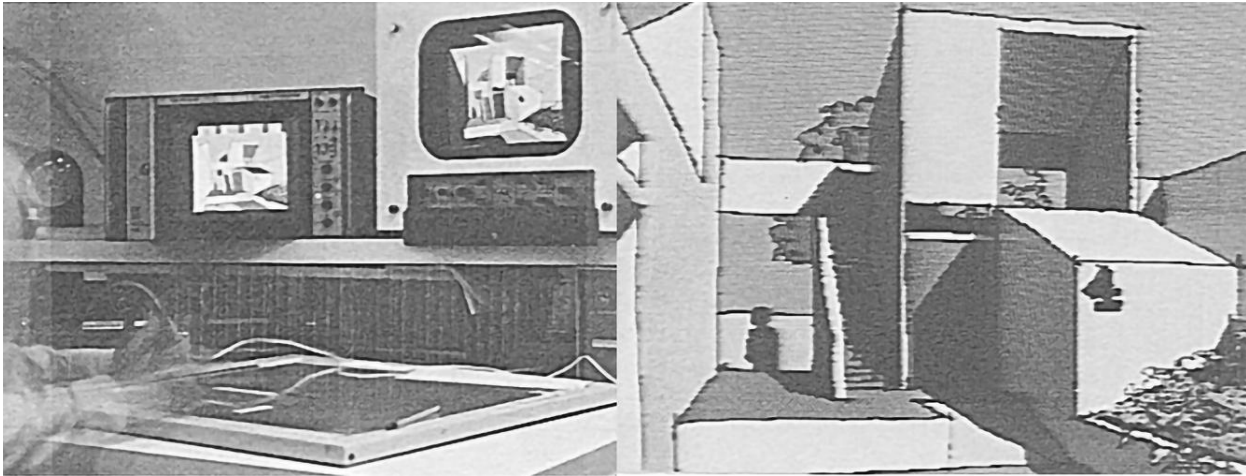

Figure 1. Architecture-by-Yourself: An experiment with computer graphics for House Design. Source: Adapted from Weinzapfel and Negroponte, 1976.

Mechanical Engineering discussed visions similar to Engelbart's (Coons, 1963). They addressed the possibility of using computing more explicitly in the design processes, from the building's conception to construction. Coons (1963) described that they outlined a system that would "use the creative and imaginative powers of man and the analytical and computational powers of the machine" (Coons, 1963, p. 300). Based on this premise, Coons and Ross incorporated the postulates of Engelbart (1962) into the proposals of their research project Computer-Aided Design, coordinated by Ross. This project aimed to apply data processing concepts and techniques for the design of mechanical parts and the development of automatic programming systems for numerically controlled machines and tools (Ross, 1961; Ross & Rodríguez, 1963), consolidating itself as a reference for important research in the area, such as the doctoral research of Ivan Sutherland (1963) and Charles Eastman (1968).

Eastman (1970) published an analysis of intuitive design processes based on computer bases and, a year later, published a computational basis (Eastman, 1971) that, in terms of Ashby (1956) and Engelbart (1962), would expand designers' ability to develop design process activities. Also in the 1970s, the research group Architecture Machine Group (AMG), founded by Nicholas Negroponte and Leon Groisser, initiated the research project Architecture-by-Yourself: An Experiment with Computer Graphics for House Design, which, researching computational graphics, sought to develop systems that assisted non-technical actors in designing their own rooms (Figure 1) (Weinzapfel & Negroponte, 1976).

At the same time, in the United Kingdom, applying systemic and information control principles, four research groups were consolidated as a reference in the research of information description models and systems (Figure 2). As can be corroborated in Ingram (2020), part of the source codes of BIM-based computer programs, such as Revit and Archicad, come from the fruits of the research of these research groups.

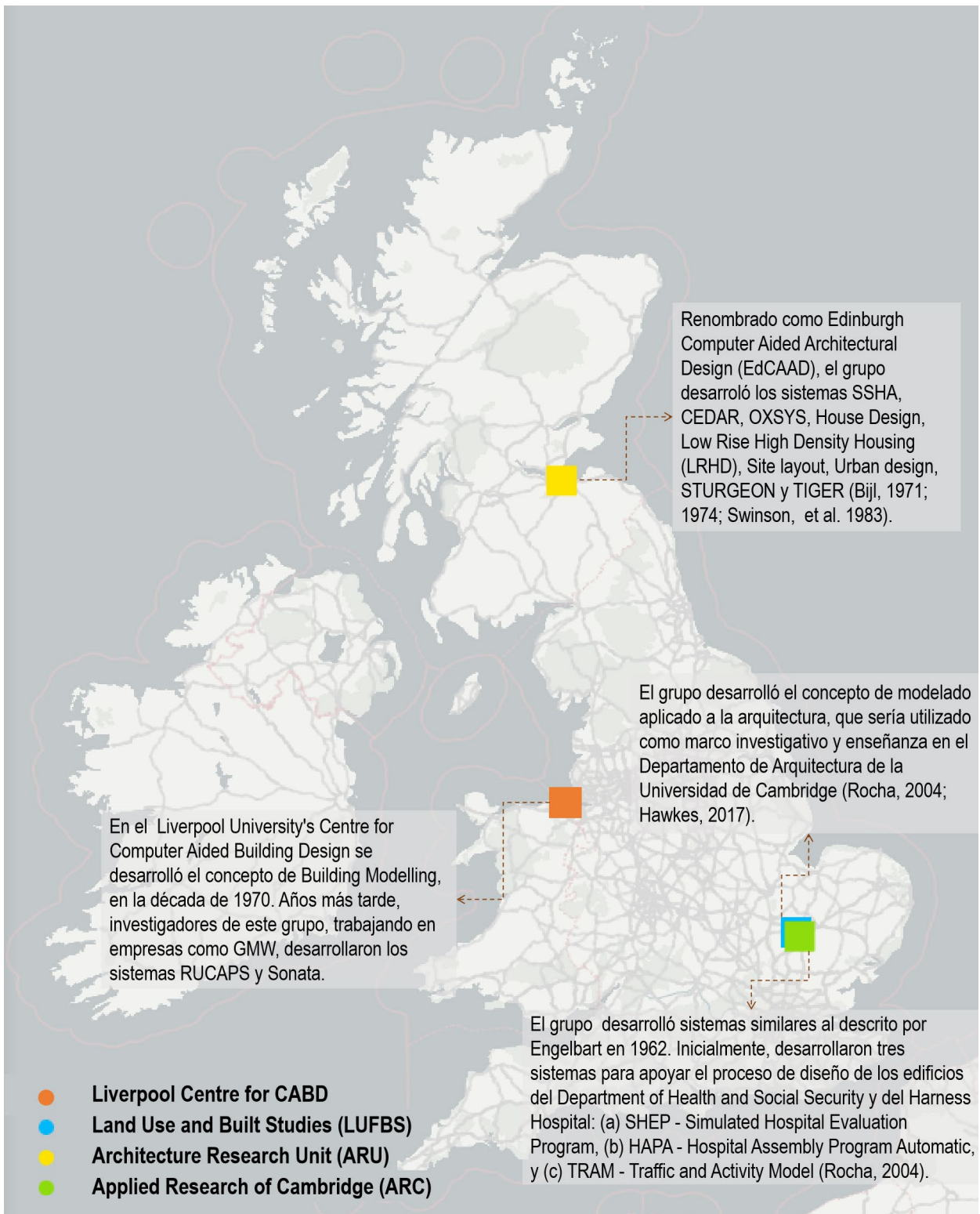

Figure 2. Research groups in the UK. Source: Preparation by the authors.

The American computational systems of the 1960s and 1970s were developed in close connection with Cybernetic Theory (Wiener, 1948), the Mathematical Theory of Communication (Shannon, 1948), and Conversation Theory (Pask, 1976). This connection can be attributed, to some extent, to the funding from institutions related to military research and that used premises of cybernetics, such as the Advanced Research Projects Agency (ARPA), the Air Force Office of Scientific Research, and the Army Engineer Division, Construction Engineering Research Laboratory (CERL). The research report of the Computer Aided Engineering and Architectural Design System (CEAEADS), prepared by the Daniel, Mann, Johnson & Mendenhall architecture office (DMJM) for the CERL, financed by the Army Engineer Division, evidences the contribution of a wide network of researchers, including architects such as Charles Eastman, William Mitchell, Robert Stults and Nicholas Negroponte (DMJM, 1979). These professionals, affiliated with diverse research groups and universities, conducted studies commissioned by military institutions, demonstrating the interconnection between academic research and military interests. The particularity of the contributions of Eastman (1968; 1970; 1971; 1972) and Negroponte (1970; 1975) is noteworthy.

The works of Eastman (1968; 1970; 1971; 1972), especially those published in the 1960s and 1970s, reflect a constant dialog with communications from researchers interested in human behavior, brain functioning, and cybernetics. Eastman (1970) noted that his approach was grounded “[...] in the work of Newell, Shaw, Simon, Hunt and others who use information processing concepts to study concept formation and problem-solving” (p. 23). We highlight the work Adaptive Conditional Architecture (Eastman, 1972), which derives from cybernetics, “focusing on the dynamic and constantly changing aspects of the physical environment, rather than the static and monumental aspects” (p. 52). This shows that the works, both theoretical and computational, emerged from experiments driven by the theories that permeated the intellectual and social context of the United States, especially cybernetics. On the other hand, Negroponte’s work was strongly influenced by Conversation Theory (Pask, 1976) and by the participatory design processes of the Franco-Hungarian architect Yona Friedman (1971). In the middle of a series of posts about Conversation, the English cyberneticist Gordon Pask came up with the text Artificial Intelligence in 1972, published as an introduction to a chapter of Soft Architecture Machines (Negroponte, 1975). This demonstrates a clear articulation between the fields of Cybernetics and Architecture.

In Europe, design processes and computer programs oriented to the design process benefited, particularly -but not exclusively - from the systemic and cybernetic contributions of Pask (1969; 1976) as well as from the participatory proposals of the Archigram group and the architect Lucien Kroll (1994). We highlight the vast academic production on the subject, especially, but not limited to, the book Advanced

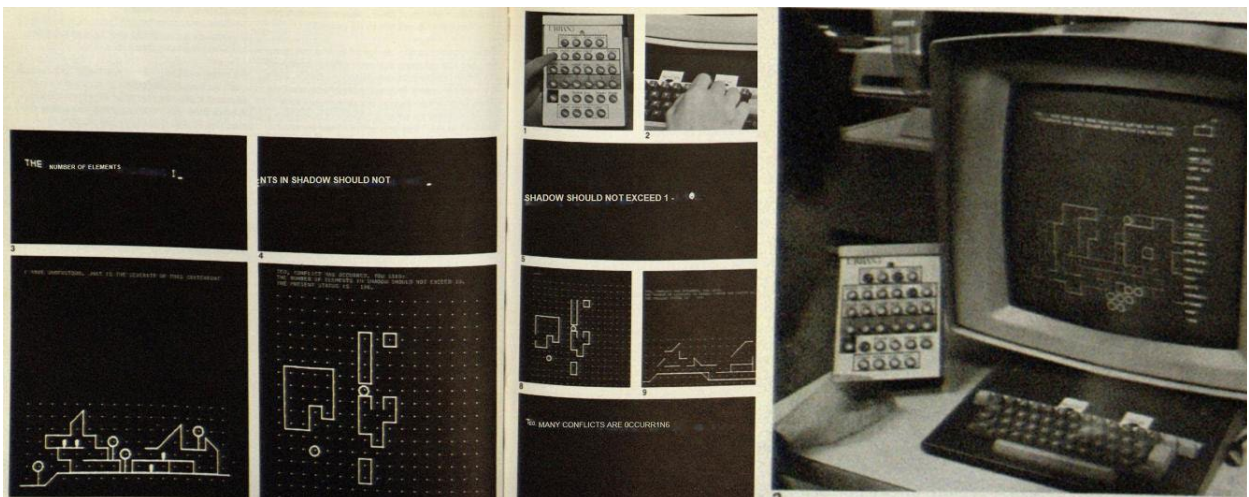
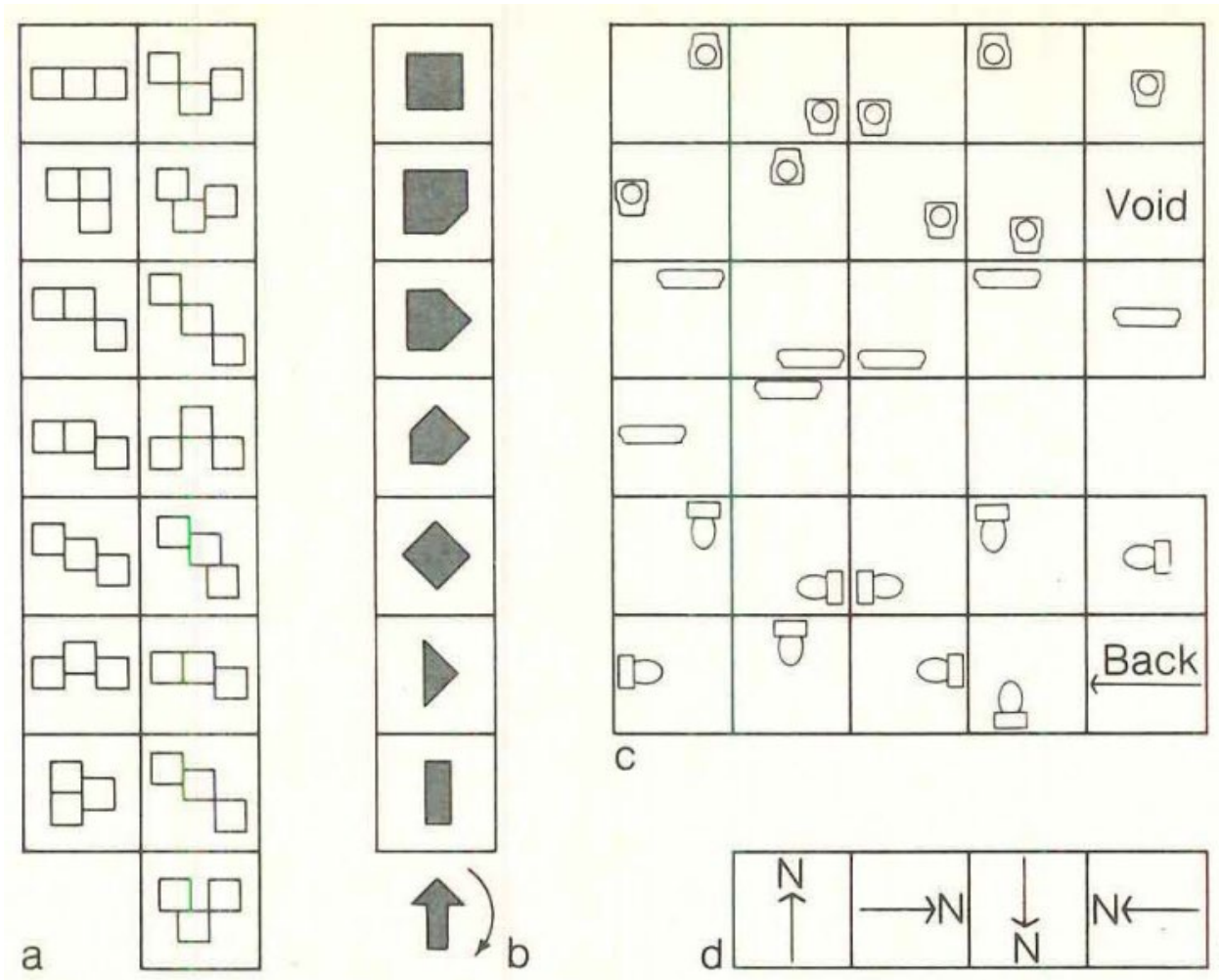

Figure 3. Diagram of the options of Flatwriter. Source: Friedman, 1971.

Figure 4. URBAN5 Software. Source: Adapted from Negroponte, 1970.

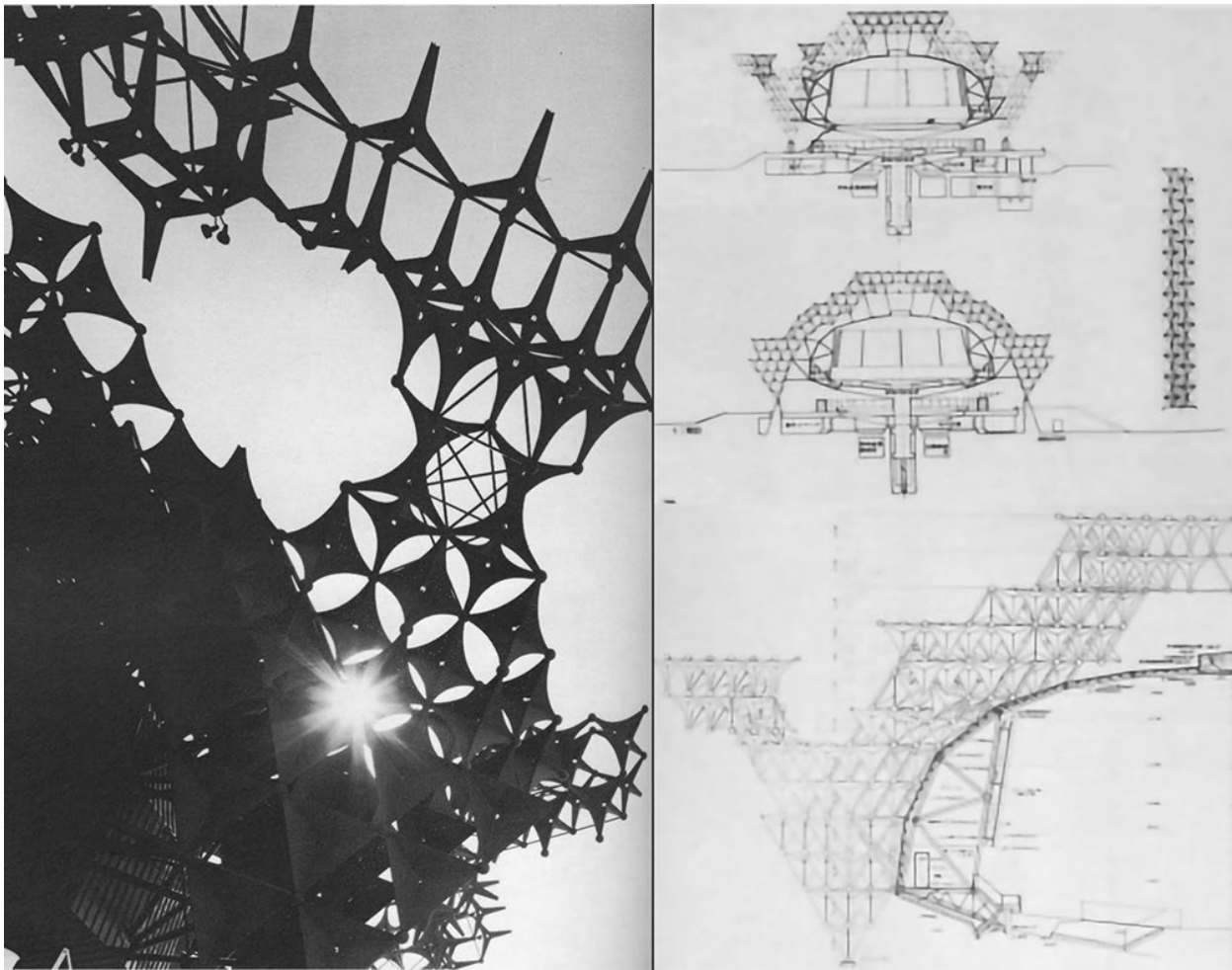

Figure 5. Toshiba Ihi Pavilion, Expo 70, 1970. Source: Adapted from Kurokawa, 1977.

Computer Graphics: Economics Techniques and Applications (Parslow & Green, 1971) and the Annals of the Congress, Design Participation – Proceedings of the Design Research Society Conference (Cross, 1972). At the same time, in France, notions of citizen participation in design decision-making, derived from structuralism (Rocha, 2004), also contributed to the formulation of software that assisted participatory design processes and described the construction information. In this context, Friedman (1971) conceived the Flatwriter software (Figure 3), designed to offer non-technical tools for selecting and printing the preferences of their future room. His proposal was presented at the Osaka World Exhibition in Japan in 1970 and influenced a significant number of formulations of computational systems, such as URBAN5 (Figure 4) (Negroponte, 1970). It is noteworthy that, at the same exhibition, the metabolist architect Kisho Kurokawa presented the Toshiba Ihi Pavilion project (Figure 5), whose structural calculations were made with the assistance of a computer (Kurokawa, 1977).

Architecture journals also played an essential role in disseminating technological advances, which influenced the formulations and developments of BIM. The American journal *Progressive Architecture* (1920-1995) built a

valuable collection of pioneering works on systems oriented to architecture and, specifically, to the design process. The issues of 1971 stand out, where influential works on participatory design processes were published, such as Flatwriter (Friedman, 1971), and systems with interconnected databases developed by architecture offices (Interior design, 1971, p. 84). Also, in London, the Computer-Aided Design Journal inaugurated the International Conference and Exhibition on Computers in Engineering and Building Design (1974). This event served as a discussion platform for the growing group of professionals involved with Computer-Aided Building Design (CABD).

This item gathered a set of connections between cybernetics and the panorama of the genesis of the development of architecture-oriented computational bases, aiming to verify the theoretical foundations of the BIM formulations, as in the cases of Eastman, Negroponete, Sutherland, and Friedman. The 1960s and 1970s marked the birth of software, once a broad set of computer programs was unfolded from the first formulations of these architects and from the British groups CCABD, LUBFS, ARC, and EdCAAD. Despite the geographical diversity of the contributions, they are all located in North Atlantic countries.

Cybernetics and design processes

The central decades of the 20th century constituted a scenario of intellectual ferment strongly related to the post-war and Cold War situations. During those decades, using cybernetic postulates, the influences of the knowledge produced in the period of the space race and by the Advanced Research Projects Agency (ARPA), on computing and architecture. This scenario contributed to the weaving of connections between cybernetics, computing, and design processes, which led to the computerization of architectural thinking and design processes in BIM. It encompassed influences, impositions, and concordance of visions on the production of architecture in an era of computational advances and the need for urban reconstruction.

In the American context of the imminent threat of nuclear war, Wiener, Deutsch, and Santillana (1950) applied the organizational principles discussed in their recently published book, *The Human Use of Human Beings*, to the field of urbanism. They conceived the city as a network of communications and flows analogous to the human body. Martin (2005) considers that, for Wiener, the city should be understood as a great communicative organism (Martin, 2005), a vision that coincides with those mentioned by Alexander (1965) and by the English cyberneticist Gordon Pask (1969; 1976), who stood out for his extensive contribution to the articulation between cybernetics and architecture. Cedric Price (2001) recalls that Pask's first contact with architects occurred in 1960 when he was a guest in the Fun Palace project. Price (2011) noted that Pask's contribution to the design of the Fun Palace was invaluable, providing executive and, mainly, cybernetic solutions, which determined the program and dimensions of the project (Figure 6). For the English cyberneticist,

DEVELOPMENT

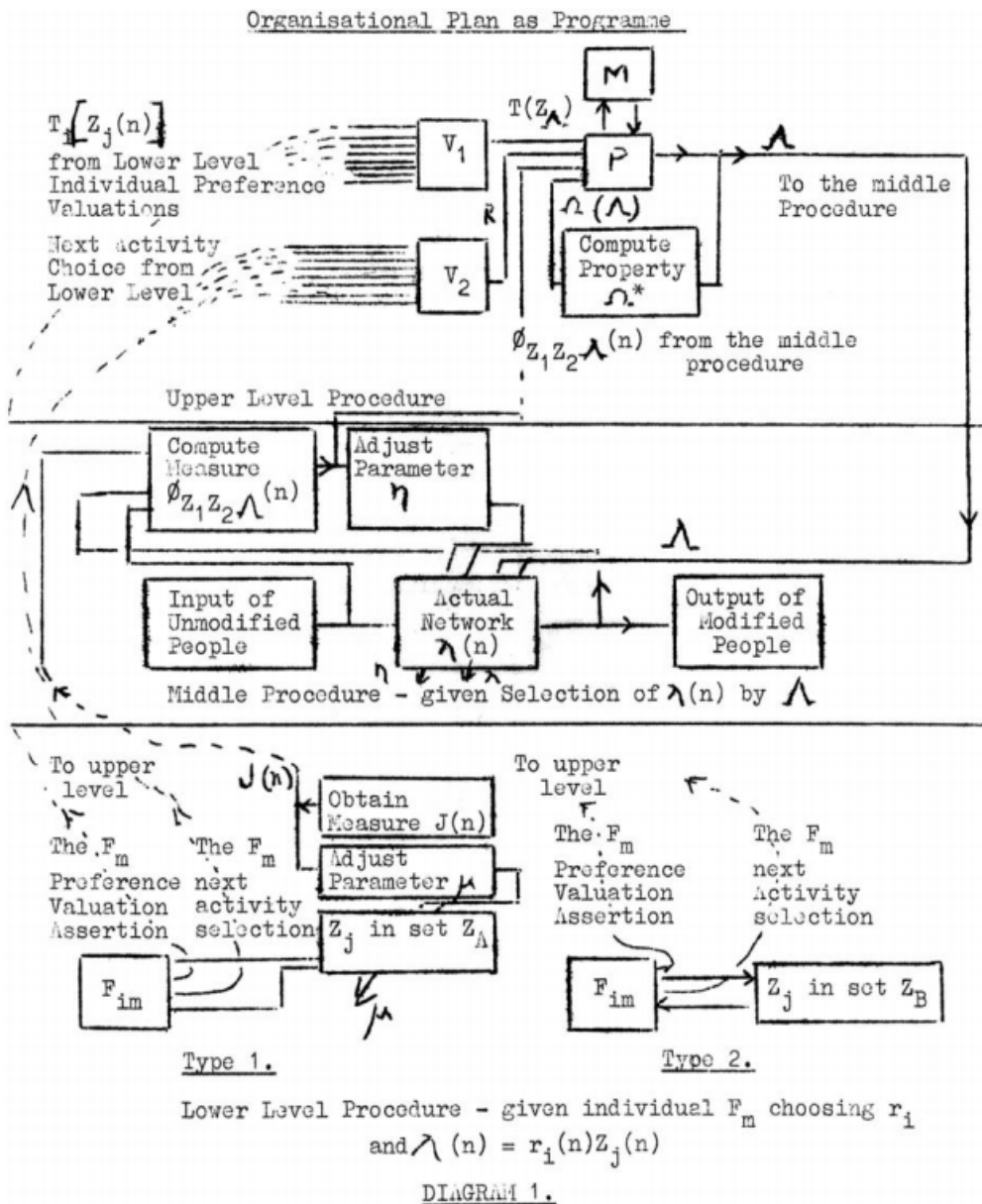

Figure 6. Cybernetic diagram of the Fun Palace, by Gordon Pask. Source: Mathews, 2006.

architects were the first designers of dynamic systems, driven to an interest in the organizational properties of designed systems, communication, and control (Pask, 1969). Such an argumentation on the relationship between cybernetics and architecture is based on the premises of Conversation Theory (Pask, 1976) which, in line with Second-order Cybernetics, considers the influence of the observer on the observed systems.

Pask's conception (1969; 1976) coincides with the Archigram group's understanding of architecture as a system that includes its observer. Sadler (2005) indicates that Archigram "promoted architecture as a complex, dispersed service situation, completed only by the active participation of the observer; in a fully functioning cybernetic environment [...]" (p. 113). Both Pask (1969; 1976) and Archigram identified potentialities in digital

technologies for observing complex systems, be they design processes, architectural units, or cities. It is important to note the architecture-oriented computational pioneering of both. The works of the English cyberneticist promoted the theoretical transfer and application of cybernetics to architecture. They discussed cybernetics itself, which occurs, according to the Theory of Communication (Shannon, 1948), without noises in the transmission channel. It was the cybernetic himself who, applying cybernetic theory to the field of architecture, developed computational bases to assist design processes. At the same time, he reflected on the processes and theorized them. According to Mathews (2006), Pask translated interaction processes and dynamics between users and control systems of the Fun Palace into structured information, stating this in diagrams to establish spatial reconfiguration strategies and providing an "operational spatiotemporal matrix of a virtual architecture" (Mathews, 2006, p. 45). Archigram made direct analogies to the computer and its operation, alluding to an architecture of plug-ins and connections allied to a systemic approach (Sadler, 2005): In *Plug-in City*, the software is the movable and interchangeable architectural units; the hardware is the fixed structure of the city, the support where the architectural units are connected (Rouillard, 1994; Silva, 2004).

The residential building proposal of *Plug-in City* refers to portable reinforced concrete unit capsules that could be connected in cities. These were also proposed as machines designed for easy connection and disconnection of capsules (Silva, 2004). Similarly, in 1959, based on biological and systemic notions (Von Bertalanffy, 1976), the metabolicists proposed developing and adapting mega-interconnected structures in which "living cells, as in the work of Kisho Kurokawa, would be reduced to prefabricated cocoons, connected to huge helical skyscrapers" (Frampton, 2003, p. 344). This scenario of proposing and developing mega structures arranged to connect capsules occurred in parallel to Friedman's proposals on organizing urban space by means of spatial mega structures (Miyasaka, 2011).

In this work, it has been proposed to bring together the Archigram group, the Metabolist movement, and Friedman based, firstly, on the fact that they shared the historical situation of the years following the Second World War when city planning was under reconstruction, and, secondly, on the similarities in their participatory approaches to design and the use of digital technologies. These similarities derived from the significant influences of General Systems Theory and the field of Cybernetics for the "emergence of an improvisational reasoning in architecture and projects of spaces, objects, infrastructure, and even cities" (Rocha, 2015, p. 108). Silva (2004) argues that the capsule houses also had flexible characteristics, comprising smaller and articulated elements, allowing the inhabitants to reconfigure them dynamically. Regarding the Metabolist movement, there are "traces of a participatory

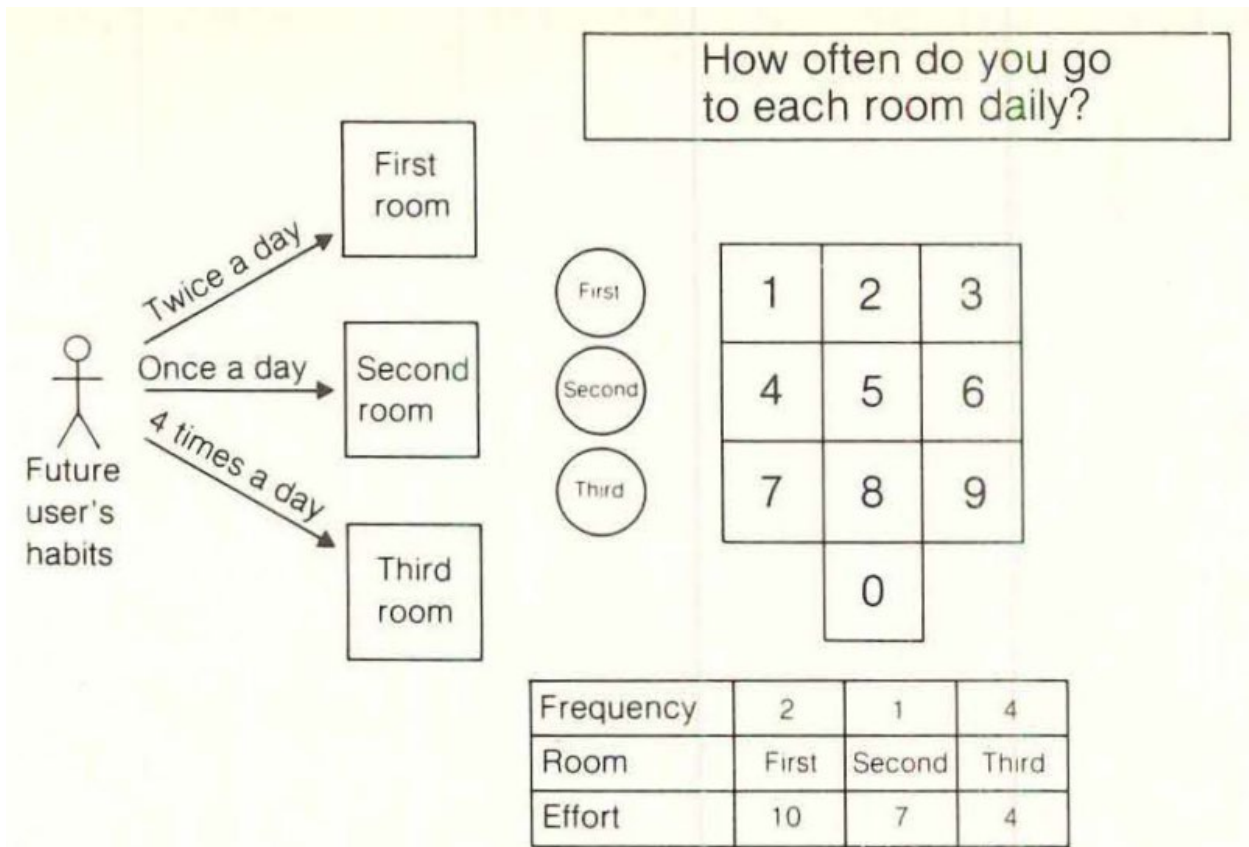
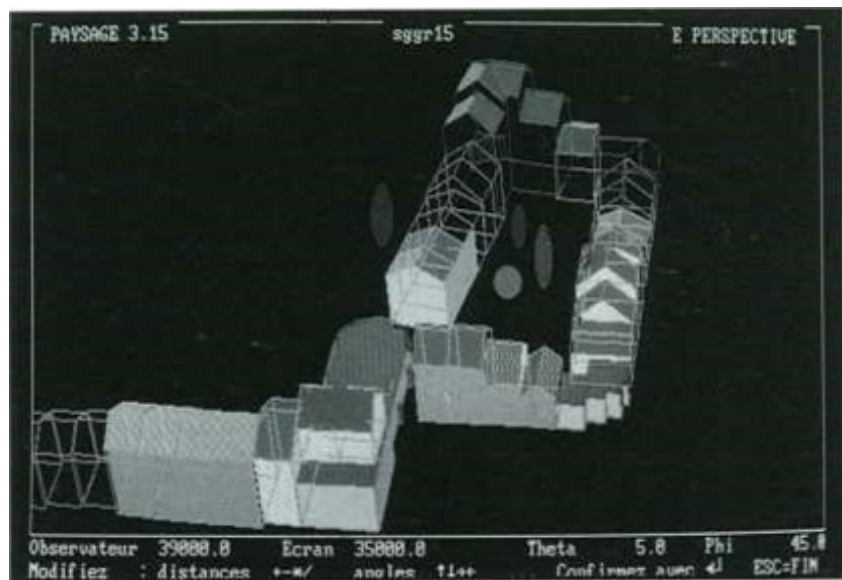

Figure 7. Diagram of translation of ways of life and use of environments. Source: Friedman, 1971.

Figure 8. Software developed by the Lucien Kroll office in 1981. Source: Kroll, 1994.



opening and individual valorization manifested in the desire to offer, through these systematic methods, the possibility that each individual could create their own room, according to their tastes and pocketbook" (Rocha, 2015).

Friedman (1971; 1973) notes the need to open spaces of expression for individuals and inform them about their decisions' risks and possible implications (Figure 7). He designed processes that avoided noise in the transmission of information, so as not to compromise the reception of the message sent (Friedman, 1971; 1973). In fact, as Miyasaka's study (2011) shows, Friedman looked more deeply into participatory dynamics. Veloso and Pratschke (2013) also indicate that Friedman investigated design in architecture as an informational process that stimulated "the diversity of human behavior and new types of social organization" (p. 354).

The Belgian architect Lucien Kroll and the Dutch architect John Habraken make up a second group of architects who marked the studies on design processes that stimulate and are open to emergencies, to paraphrase Morin (2011). The approach of Kroll (1994) regarding participatory processes starts from the search for design guidelines where, through the observation of the daily life of the communities, the concerns were contemplated as they are identified, instead of designating priorities to the problems, making it necessary to involve all urban inhabitants. Kroll (1994) stated that starting from disorder, his search was based on encouraging the development of self-organized social autonomies while inviting escape from what he called architectural clumsiness, which lacks basic questioning (Kroll, 1994). Apart from being an assiduous critic of the modernist movement, Kroll (1994) was noted for using software to develop techniques for people to design their own spaces (Figure 8).

In the Netherlands, the architect John Habraken (1961), a pioneer of the participatory architecture movement, published the book *De Draggers in de Mensen*, where he presented a radical alternative to the mass construction of rooms. Like Kroll, Habraken lays the foundation for the production of identical living spaces and responds to this situation—in a post-war moment—with the concept of supports, which attribute the general design to the architect and the design of the domestic space to the inhabitant (Habraken, 1961). Although Habraken did not contemplate the use of digital technologies much at the time of his book's publication, he presented to MIT in 1996 a report reflecting on the professional practice of architecture and addressing the influence of digital technologies (Habraken, 1996). While he notes a departure from the architect's traditional role, he clearly indicates a computerized practice.

"It is, however, Alexander's most incisive contribution to the computerization of design processes, objectifying the inclusion of inhabitants" (Tramontano & Trujillo, 2019, p. 3). In *The Architecture Relevance of Cybernetics* (1969), Pask (1969) indicated that abstract cybernetics can also be interpreted as a global architectural theory,

referring to the potential of architectural design to create responsive open systems. He also highlighted the cybernetic advances of the architects Christopher Alexander and Nicholas Negroponte: "Alexander, concerned with the logic of form, traces essentially cybernetic concepts [...], I am eager to follow the pragmatic development of cybernetic ideas and see them emerge in the history of architecture" (p. 76). In *Community and Privacy: Toward a New Architecture of Humanism*, Chermayeff and Alexander (1963) worked on describing the structure of an urban organism using computer programs. Moreover, in the classic essay, *A City is Not a Tree* (1965), they emphasize two fundamental issues.

The first is that the city is a complex system and that any attempt to understand it requires a systemic approach [...]. The second is the risk that, because it is based on technical-scientific knowledge as a guarantee of its rationality, modern urban planning concentrates excessive decision-making power in the hands of designers, planners, urban administrators, and real estate developers, ignoring, in the process, the real city, the lifestyles, and the, in general, conflicting aspirations of its inhabitants" (Tramontano et al., 2020, p. 55).

Seeking a quantitative approach to design, Alexander defended that any element that could be designed was a problem to be solved methodically as a system: "Using the computer, the designer defines a mathematical model of the behavior of the problem, creating a hierarchy of various subsystems with strong interaction" (Veloso, 2012, p. 497). For his part, Habraken (1961) considers that, by presenting each pattern as a solution to a problem, Alexander's argumentation acquires an unnecessary deterministic meaning for participatory design processes. Even so, Alexander played a crucial role in the computerization of architectural thinking, in particular, introducing the notion of Pattern Languages (Alexander et al., 1977). In addition, as Richard P. Gabriel (1999) emphasizes in his book *Patterns of Software: Tales from the Software Community*, software developers, especially object-oriented software, widely welcomed Alexander's propositions. As with Pask for the Fun Palace (Mathews, 2006), Alexander stated and systematized the dynamics of human behavior, producing a catalog of structured and interconnected information so that it could be thought through digital technologies (Alexander et al., 1977).

CONCLUSIONS

In this work, the design processes in BIM were observed as the configuration of a fabric of metatheoric, computational, and design process advances, derived from a process of more than fifty years of computerization of architectural thinking. Based on a retrospective approach, interdependent articulations between these fields were presented, considering the historical and socio-political contexts that inspired questions about participatory and collaborative design processes influenced and assisted by digital technologies and cybernetics. This scenario of parallels cemented the foundations, first, of a process of change in the design processes and, secondly, of a process of computerization of architectural thinking that extends to the present.

Consequently, it can be inferred that the formulation and advancement of BIM is a continuation of the efforts to incorporate computational thinking into the design processes once it is intrinsically linked to the objective of managing and declaring a more significant amount of information from the design process, based on cybernetic and computational principles, with the support of technological advances.

The cybernetic premises, propositions, and developments of Pask, Friedman, Alexander, Kroll, Habraken, Eastman, Negroponte, Sutherland, Archigram, and the Metabolists were brought together in the same cognitive-investigative sequence according to their contributions to the processes of design and computerization of architectural thinking. The observation, organization, and active control of dynamic systems were identified as a common denominator, as were design processes open to the interaction of the parts. They also share the characteristic of contemplating using digital and information technologies, although at different levels and scales.

Archigram reflected on an interconnected society that would use information and communication technologies. Although he did not examine the implications of his futuristic proposals closely, he provoked questions about using data to produce and manage such organisms. The Metabolists, in turn, had a more mature view of Western technologies. It was found that the Metabolists used software, both in the design processes and in the buildings themselves. Friedman (1971; 1973) contemplated using software through organized design processes focused on participation, encouragement, and acceptance of emergencies. Alexander (Alexander et al., 1977), for his part, developed the concept of Pattern Languages in the field of architecture. He contributed profoundly, although not exclusively, to software development, especially in object-oriented software. The search for non-hierarchical organizational structures supported by conversation processes was also identified to stimulate emergencies and system reorganization. Tramontano et al. (2020) highlight that the works carried out by Kroll and Alexander "were precursors of the introduction of algorithmic thinking in architecture and helped to construct procedures that, later, would be useful for the conception of current parametric programs, especially those based on BIM" (p. 55). It is considered pertinent to place the works of Friedman and Negroponte within this group of precursors.

In Europe, especially in the United Kingdom and France, cybernetics gained more followers, contributing to the emergence of other ways of approaching design processes and the incorporation of cybernetic and computational thinking into the design process. Even though a movement of incorporation and study of cybernetics within the field of Art and Architecture also occurred in Latin America, with exponents such as Jorge Glusberg (Glusberg, 1972) and The Group of the Thirteen (Mariategui, 2024; Marchesi, 2017), in Argentina, and Jaime Garretón Risopatrón (Garretón, 1975; Araneda, 2022) in Chile, no records were found that directly relate this movement to the development of BIM.

It was understood that the computerization of architectural thinking, despite its strict dependence on the use of digital technologies, initially needs

to structure the information since computerization is the process through which dynamics, knowledge, and behaviors are translated into information that can be processed by digital technologies (Zuboff, 1988), such as those of BIM programs. Therefore, efforts to translate processes into declared and arranged information to feed data banks are as necessary as efforts to introduce algorithmic-computational thinking into design processes. Thanks to cybernetic visions of observation, control, and organization, Pask, Negroponte, Kröll, Alexander, Friedman, and Eastman acted in both spheres simultaneously. Then, clear articulations between cybernetics and design processes were identified, which instigated and theoretically based computational bases that, among other things, contributed to the production of the current computerized design processes in BIM. This statement is also verified by the discovery of the cybernetic foundations of research that directly drove the advancement and development of BIM, such as those carried out by Charles M. Eastman (1971; 1972; Eastman et al., 2011) or those made by the UK groups. The importance of the programs developed in the United Kingdom, mainly in the Liverpool Centre for Computer-Aided Building Design, is highlighted since they are the direct predecessors of the most widely used BIM-based programs in the contemporary production of architecture.

Finally, we cannot help but notice that computer programs oriented to design processes, mainly those based on BIM, have been developed to assist North Atlantic architecture models, contributing to perpetuating their imposition on other global lines. This means that design processes are not exempt from the non-neutrality of technology, mainly Software and Information and Communication Technology Services, revealing the need to discuss the issue critically.

BIBLIOGRAPHIC REFERENCES

Alexander, C. (1965). A city is not a tree. *Architectural Forum*, 122(1), 58–62. <https://www.taylorfrancis.com/chapters/edit/10.4324/9780203094235-18/city-tree-christopher-alexander>

Alexander, C., Ishikawa, S., Silverstein, M., Jacobson, M., Fiksdahl-King, I., & Angel, S. (1977). *A Pattern Language: Towns, Buildings, Constructions*. Oxford University Press. [PDF] https://arl.human.cornell.edu/linked%20docs/Alexander_A_Pattern_Language.pdf

Ashby, W. R. (1956). Design for an Intelligence-Amplifier. En *Automata Studies*, 34, 215–234. Princeton University Press EBooks. <https://doi.org/10.1515/9781400882618-011>

Araneda, C. (2022). Jaime Garretón's cybernetic theory of the city and its system: a missing link in contemporary urban theory. *AI & Soc* 37, 1179–1189. <https://doi.org/10.1007/s00146-021-01349-z>

Bijl, A. (1971). Computer Aided Architectural Design en R. D. Parslow, & R. E. Green (Eds.), *Advanced Computer Graphics* (pp. 433–448). Springer: https://doi.org/10.1007/978-1-4613-4606-7_25

Bijl, A. (1974). Research in progress. *Computer-Aided Design*, (6)3, 183–186. <https://www.sciencedirect.com/journal/computer-aided-design/vol/6/issue/3>

Bourke, R., & Skinner, Q. (Eds.). (2022). *History in the Humanities and Social Sciences*. Cambridge University Press. <https://doi.org/10.1017/9781009231053>

Chermayeff, S., & Alexander, C. (1963). *Community and Privacy: toward a new architecture of humanism*. Doubleday.

Coons, A. (1963). An outline of the requirements for a computer-aided design system. In Proceedings of the May 21-23, 1963, *Spring Joint Computer Conference* (AFIPS '63 (Spring)). Association for Computing Machinery, USA, 299–304. <https://doi.org/10.1145/1461551.1461588>

Cross, N. (Ed.). (1972). *Design Participation: proceedings of the design research society conference, 1971*. Academy Editions.

DMJM. (1979). *Computer Aided Engineering and Architectural Design System* (CEAEADS). U.S. Army Construction Engineering Research Laboratory. [PDF] <https://apps.dtic.mil/sti/tr/pdf/ADA065827.pdf>

Dubberly, H., & Pangaro, P. (2015). How Cybernetics Connects Computing, Counterculture, and Design. *Hippie Modernism: The Struggle for Utopia*. Walker Art Center. <https://www.dubberly.com/articles/cybernetics-and-counterculture.html>

Dounas, T., Lombardi D., & Jabi, W. (2021). Framework for decentralised architectural design BIM and Blockchain integration. *International Journal of Architectural Computing*, 19(2), 157-173. <https://doi.org/10.1177/1478077120963376>

Eastman, C. (1968). *Explorations of the cognitive processes in design* [Tesis de Doctorado, Carnegie-Mellon University]. Repositorio Institucional.

Eastman, C. (1970). On the analysis of intuitive design processes. En T. Moore (Ed.), *Emerging Methods in Environmental Design and Planning*. 21–37. [PDF] <https://users.metu.edu.tr/baykan/arch467/Readings/Eastman.pdf>

Eastman, C. (1971). GSP: a system for computer-assisted space planning. *Proceedings Of The June 1971 Design Automation Workshop On Design Automation - Dac '71*. 208–220. <http://dx.doi.org/10.1145/800158.805073>

Eastman, C. (1972). Adaptive Conditional Architecture. En N. Cross (Ed.), *Design Participation: proceedings of the design research society conference, 1971*. 51–57

Eastman, C., Teicholz, P., Sacks, R., & Liston, K. (2011). *BIM handbook: A guide to building information modeling for owners, managers, designers, engineers, and contractors* (2nd ed.). Wiley.

Engelbart, D. (1962). *Augmenting Human Intellect: A Conceptual Framework*. Stanford Research Institute. [PDF] https://www.doungengelbart.org/pubs/papers/scanned/Doug_Engelbart-AugmentingHumanIntellect.pdf

Frampton, K. (2003). *História Crítica da Arquitetura Moderna*. Martins Fontes.

Friedman, Y. (1971). The Flatwriter: choice by computer. *Progressive Architecture*.

(52) 98-101. [PDF] <https://www.semanticscholar.org/paper/The-Flatwriter%3A-Choice-by-Computer-Friedman-Derix/6679d84d064a31161298777f21812d69fdb2627>

Friedman, Y. (1973). *Hacia una arquitectura científica*. Alianza Editorial.

Gabriel, R. (1999). *Patterns of Software: Tales from the Software Community*. Oxford University Press.

Garretón, J. (1975). *Una teoría cibernética de la ciudad y su sistema*. Ediciones Nueva Visión.

Glusberg, J. (Ed.). (1972). *Arte de sistemas en la III Bienal de arte Coltejer*. CAYC Centro de Arte y Comunicación. [PDF] https://monoskop.org/images/d/d0/Arte_de_sistemas_el_CAYC_y_el_proyecto_de_un_nuevo_arte_regional_1969-1977_2013.pdf

Habraken, J. (1961). *De dragers en de mensen: Het einde van de massawoningbouw*. Stichting Architecten Research.

Habraken, J. (1996). *Tools of the Trade: thematic aspects of designing*. The MIT Press.

Hawkes, D. (2017). Bridging the cultures: architecture, models and computers in 1960s Cambridge. *Interdisciplinary Science Reviews*, 42(1-2), 144–157. <http://dx.doi.org/10.1080/03080188.2017.1297160>

Ingram, J. (2020). *Understanding BIM: The Past, Present and Future*. Routledge.

Interior design: Designer's utopia?. (1971). *Progressive Architecture*, 7, 84–87. [PDF] <https://usmodernist.org/PA/PA-1971-07.pdf>

Kroll, L. (1994). The Voice of Libertarian Socialism en R. Van Toorn, & O. Bouman (Eds.), *The Invisible in Architecture*. 396–403.

Kurokawa, K. (1977). *Metabolism in Architecture*. Studio Vista.

Martin, R. (2005). *The organizational complex: architecture, media, and corporate space*. MIT Press.

Marchesi, M. (2017). El Cayc y el arte de sistemas como estrategia institucional. *Sztuka Ameryki Łacińskiej*, 7, 137–163.

Mariategui, J. (06 de junio de 2024). *A Latin America Network for Art and Cybernetics: The Centre for Art and Communication (CAyC)*. 28th International Symposium on Electronic Art ISEA2023, Paris, Francia.

Mathews, S. (2006). The Fun Palace as Virtual Architecture: Cedric Price and the practices of indeterminacy. *Journal of Architectural Education*, 59(3), 39–48. <https://cast.b-ap.net/arc590s14/wp-content/uploads/sites/8/2011/09/mathews-FunPalace.pdf>

- Miyasaka, E. (2011). *RE:VISÃO: habitat nos anos 1960*. [Disertación de Maestría, Universidad de Sao Paulo]. Repositorio Institucional. https://teses.usp.br/teses/disponiveis/18/18142/tde-21062011-100129/publico/MiyasakaEL_2011.pdf
- Morin, E. (1977). *O método I. A natureza da natureza*. (2). Gráfica Europam, LDA.
- Morin, E. (2011). *Introdução ao pensamento complexo*. Sulina.
- Negroponte, N. (1970). *The Architecture Machine*. The Mit Press.
- Negroponte, N. (1975). *Soft Architecture Machines*. The Mit Press.
- Parslow, R. D., & Green, R. E. (Eds.). (1971). *Advanced Computer Graphics: economics techniques and applications*. Plenum Publishing Company Ltd.
- Pask, G. (1969). The architectural relevance of cybernetics. *Architectural Design*, 37(6), 494-496 https://cmsyntheticecologies.wordpress.com/wp-content/uploads/2014/01/pask_gordon_the-architectural-relevance-of-cybernetics.pdf
- Pask, G. (1976). *Conversation Theory: Applications in Education and Epistemology*. Elsevier Science Limited.
- Pita, J. (2021). *Colaboração comunitária em obras públicas através do uso da Modelagem de Informação da Edificação (BIM)* [Tesis de Doctorado, Universidad de Sao Paulo – Instituto de Arquitectura y Urbanismo]. <https://www.teses.usp.br/teses/disponiveis/102/102132/tde-21012022-121553/publico/TeseCorrigidaJulianoVeraldodaCostaPita.pdf>
- Pita, J., & Tramontano, M. (2023). BIM como plataforma de participação cidadã. *Gestão & Tecnologia de Projetos*, 18(1), 239–260. <https://doi.org/10.11606/gtp.v18i1.183748>
- Price, C. (2001). Gordon Pask. *Kybernetes*, 30(5-6), 819–820. <https://doi.org/10.1108/03684920110392084>
- Quin, C. A. (2019). The platonic forehand and backhand of cybernetic architecture. *Leonardo*, 52(5), 429–434. https://doi.org/10.1162/leon_a_01796
- Rocha, A. (2004). *Architecture Theory 1960-1980: emergence of a computational perspective*. [Tesis de Doctorado, Massachusetts Institute of Technology]. <https://dspace.mit.edu/handle/1721.1/28316>
- Rocha, B. (2015). *Complexidade e Improvisação em Arquitetura* [Tesis de Doctorado, Universidad de Sao Paulo]. <https://www.teses.usp.br/teses/disponiveis/16/16134/tde-08032016-152801/publico/brunomassara.pdf>
- Rocha, B. (n.d.). Territorios. (2021). *Movimento Metabolista*. https://www.territorios.org/teoria/H_C_metabolistas.html
- Ross, D. (1961). Computer-aided design. *Communications of The Acm*, 4(5), 235-236. <http://dx.doi.org/10.1145/366532.366554>

Ross, D., & Rodriguez, J. (1963). Theoretical foundations of the computer aided design system. *Spring Joint Computer Conference*. 305–322. <https://doi.org/10.1145/1461551.1461589>

Rouillard, D. (1994). Archigram. J. Dethier (Ed.), *La Ville: art et architecture en Europe, 1870-1993*. Éditions du Centre Pompidou.

Sadler, S. (2005). *Archigram: architecture without architecture*. The Mit Press.

Shannon, C. (1948). A Mathematical Theory of Communication. *Bell System Technical Journal*, 27(3), 379–423. <http://dx.doi.org/10.1002/j.1538-7305.1948.tb01338.x>

Silva, M. (2004). Redescobrimo a arquitetura do Archigram. *Arquitextos*, 48(5). <https://bit.ly/3wHLYfO>

Sutherland, I. (1963). *Sketchpad, a man-machine graphical communication system*. [Tesis de Doctorado, Massachusetts Institute of Technology]. <https://www.cl.cam.ac.uk/techreports/UCAM-CL-TR-574.pdf>

Swinson, P., Pereira, F., & Bijl, A. (1983). A fact dependency system for the logic programmer. *Computer-Aided Design*, 15(4), 235–240. [http://dx.doi.org/10.1016/0010-4485\(83\)90127-6](http://dx.doi.org/10.1016/0010-4485(83)90127-6)

Tramontano, M., & Trujillo, J. (2019). Compartilhando decisões: plataformas online para participação cidadã. *PROJETAR*, 9. Universidade Federal do Paraná. 2, 1-9. [PDF] http://projedata.grupoprojetar.ct.ufrn.br/dspace/bitstream/handle/123456789/1176/_Plataformas_online.pdf?sequence=1&isAllowed=y

Tramontano, M., Pita, J., & Sousa, D. (2020). Building Information Modelling em processos decisórios participativos. *Revista Design & Tecnologia*, 10(21), 54–69. <https://doi.org/10.23972/det2020iss21pp54-69>

Veloso, P. (2012). Christopher Alexander e o dilema do espaço (in)formado. *Proceedings of The XVII Conference of The Iberoamerican Society of Digital Graphics*. [PDF] https://papers.cumincad.org/data/works/att/sigradi2012_9.content.pdf

Veloso, P., & Pratschke, A. (2014). Uma Arqueologia de Diagramas Cibernéticos. *Proceedings of The XVII Conference Of The Iberoamerican Society Of Digital Graphics*. [PDF] <https://doi.org/10.5151/despro-sigradi2013-0067>

Von Bertalanffy, L. (1976). *Teoría general de los sistemas*. Fondo de Cultura Económica.

Von Foerster, H. (Eds.). (1974). *Cybernetics of cybernetics*, BCL Report No. 73.38. Biological Computer Laboratory, Department of Electrical Engineering, University of Illinois.

Weinzapfel, G., & Negroponte, N. (1976). Architecture-by-yourself. *Acm Siggraph Computer Graphics*, 10(2), 74–78. <http://dx.doi.org/10.1145/965143.563290>

Wiener, N. (1948-1970). *Cibernética, ou controle e comunicação no animal e na máquina*. Polígono, EDUSP.

Wiener, N. (1950). *The human use of human beings: cybernetics and society*.
Houghton Mifflin.

Wiener, N., Deutsch, K.; & Santillana, G. (1950). How U.S. cities can prepare for
Atomic War: (2 de agosto de 2024) *Life magazine*.

Zuboff, S. (1988). *In the age of the smart machine: The future of work and power*.
Basic Books.