

The effect of cutting direction and water based varnish type on sound absorption coefficient in some native wood species

Mustafa Selmani Muslu¹ <https://orcid.org/0000-0003-2971-4333>*

¹Konya Technical University. Vocational School of Technical Sciences. Department of Materials and Materials Processing Technologies. Selçuklu, Konya, Turkey

*Corresponding author: msmuslu@ktun.edu.tr

Abstract:

Noise which could be defined as disturbing sound, is becoming a major problem depending with developing technology. Controlling the noise helps raising the quality of life to higher levels. Although the intensity of the noise is not at a level that will affect human health, it should be reduced or eliminated, for better life standart. Due to the adverse effects of the noise level on health; the acoustic properties of living areas require serious consideration. Sound absorption coefficients of the materials used in the interior play an important role in providing sensory comfort depending on the volume. Natural and artificial wood are commonly used materials in interior design, especially in the construction of partition elements. In addition, wood is natural material and it has some important advantages and disadvantages. In this study the sound absorption coefficients of eastern beech and scotch pine trees, which are the most preferred materials in interior design, were investigated. For this pupose, these wood materials were cut superficially and radially according to the intersection directions, then the sample surfaces were varnished with one and two component water-based varnishes that do not contain solvent-based resin. The sound absorption coefficients of the obtained samples were determined by the impedance tube method and the results were compared statistically. It has been investigated that the obtained results could be evaluated statistically within the frequency values, besides, different results could be obtained according to the characteristics of natural wood materials, the direction of intersection and water-based varnish types. According to the findings obtained as a result of the study, it has been suggested that if natural wood material is used indoors, the superficial cross-section of East beech wood should be used according to the direction of intersection, and a two-component varnish should be used according to the varnish type.

Keywords: Aqueous varnish, acoustic properties, *Fagus orientalis*, noise, *Pinus sylvestris*, sound absorption coefficient.

Received: 30.06.2023

Accepted: 22.11.2024

Introduction

In our daily life, the adverse effect of sound and noise on human health is gradually increasing with the developing urbanization (Özkan 2001). The importance of noise control in living spaces emerges and, depending on the developing technology, efforts to reduce or eliminate noise gain more importance (Kayılı 1981).

Noise control is main risk factor that come to mind in creating suitable physical environments in the living spaces. The adverse effects of noise on life comfort increase the importance of it (Akdağ 2001).

Floor, wall, and ceiling tiles generally need to be covered to provide sound insulation in spaces. These applications are necessary for sound insulation, but also, they have to meet factors such as heat, humidity and decorative elements (Ersoy 2001).

There are intensive researchs about disturbing sounds and its source in literature. Akdağ (1999) investigated the several factors that cause high intense sounds. In their study, the ratio between the spaces of wall and the door was used for determining the sound transmission loss that occurs during sound transmission in the doors created under different conditions., Using this data, the properties of the door sections and details that increased the sound transmission loss required for spaces with different functions had been determined.

Keskin and Yılmaz (2020) determined the sound absorption coefficients of original building materials with the impedance tube method. The measurements were made in the frequency range of 250-4000 Hz. In their study, the B400 impedance tube method was preferred, and the measurements were carried out by determining the diameter of the samples as 69 mm. In

comparison, different types of natural materials and many different materials used in the construction industry were investigated, and as a result of the study, it had been obtained valuable information regarding the sound absorption performance of many different materials. investigated a new sound absorbing material that is not harmful to human health with the composite produced by using a natural material, gourd (LC) fibers. For this purpose, a composite material was produced by using gourd (LC) fibers and epoxy binders, and the sound absorption coefficients of the samples were determined by the impedance tube method. In addition, the effects of material thickness and fiber ratio parameters on the sound absorption coefficient were determined. The obtained findings were showed that the material thickness and fiber ratio were effective on the sound absorption coefficient in the test results.

Chung *et al.* (2017) investigated the effect of treatment temperature on acoustic properties of karamatsu (*Larix kaempferi* (Lamb.) Carr.) wood, which is typically used as a building material. In this study, samples were heated at 200 °C, 220 °C and 240 °C for 9-12-15 and 18 hours. The sound absorption coefficients of the treated wood samples were measured at different frequencies (250-500-1000- 2000 and 4000 Hz). As a result, it was determined that the sound absorption coefficient increased with the process temperature and time. According to the obtained results, it was postulated that the sound absorption coefficient of wood in the high frequency band range was increased significantly with heat treatment.

Tudor *et al.* (2020) investigated the sound absorption coefficients of bark-based insulation panels consisting of softwood bark spruce (*Picea abies* (L.) H. Karst) and larch (*Larix decidua* Mill.) between 125 Hz and 4000 Hz by means of an impedance tube. In this study, the highest efficiency of sound absorption was recorded at 1000 Hz and 2000 Hz for spruce bark-based

insulation boards bonded with urea-formaldehyde resin. Experimental results show that softwood bark, which was an underestimated material, could replace expensive and materials which have high carbon footprint, in soundproofing applications. Compared to wood-based composites, engineered spruce bark (with coarse-grained and fine-grained particles) could absorb sound better than medium density fiberboard (MDF), particleboard, or oriented particle board (OSB). For this reason, sound absorption coefficient values had determined that insulation panels based on tree bark could be used as structural elements for noise reduction in residences.

Kolya and Kang (2021) carried out a study to determine the positive effects of hygrothermal effect on paulownia (*Paulownia coreana* Uyeki), which is tree species grown in Korea and mostly used for designing home furniture, musical instruments, plywood, and particleboard. Beside the softening and improving properties of wood material, the effect of hygrothermal treatment on sound absorption coefficient was investigated. As a result of the study, it was determined that the wood material hygrothermally processed at temperatures between 90-120 °C, had better sound absorption coefficient than the raw wood material.

Choe *et al.* (2018) investigated the sound absorption properties of NaOH treated wood fibers and polyurethane composite foams. In this study, wood fibers was firstly treated with NaOH, then it was added to the foam in order to increase the sound absorption coefficient of polyurethane foams by increasing the compatibility between the wood fibers and the polyurethane matrix. In this study, wood fiber-PU composite foams were produced to increase the sound absorption efficiency of unfilled foam. For this purpose, firstly the optimum wood fiber amount in polyurethane composite foams was determined by considering the porous morphology as well as the sound absorption coefficient. Obtained results showed that the sound

absorption coefficients caused increased due to the usage of an optimum level of coupling material (NaOH). However, it was determined that excessive use of silane bonding (APTES) material affects the sound absorption coefficient negatively.

Wassilief (1996) investigated the sound absorption coefficient of wood fibers and sawdust of New Zealand pine (*Pinus radiata* D. Don) tree, which have air flow resistance, porosity, and curvature, by using the Rayleigh model. In addition, in this study, one-parameter empirical method was compared with the Delany and Bazley methods, and it was found that these methods showed close match for wood fiber samples.

Yang *et al.* (2003) investigated sound absorption properties of composite material consists of urea-formaldehyde glue, rice sticks and wood splinters. The obtained results for this material were compared with wood-based composite materials. As a result of this study, it was determined that the newly designed composite-based material showed a better sound absorption feature than other boards.

Ayan *et al.* (2012) conducted a study to compare the sound absorption coefficients of the laminated panels made of Scots pine (*Pinus sylvestris* L.), iroko (*Milicia excelsa* (Welw.) C.C.Berg) and Uludağ fir (*Abies bornmulleriana* Mattf.). The sound absorption coefficients of the Scotch pine panels were found to be higher than that of the iroko panels. In addition to that, the highest sound absorption coefficient in the range of 160-200 Hz frequency was obtained in flat panels, while in the 400-1000 Hz frequency range it was obtained in perforated panels.

Kaya *et al.* (2017) determined the sound insulation properties of fibers obtained from natural materials. The sound absorption coefficients of many different natural products were examined.

As a result of the findings, it was determined that the increase in the physical properties of natural fibers also increased the acoustic properties positively.

In this study, the effect of cutting direction and the type of applied water-based varnish on sound absorption coefficients of scots pine (*Pinus sylvestris* L.) and eastern beech (*Fagus orientalis* L.) were investigated for the first time. Wood material, which is a natural material, is an important product in interior decoration and is preferred in theater and music performances due to its sound properties. Sound properties of wood materials are important in terms of evaluation in various usage areas. The propagation and absorption of sound takes place in the natural wood material. In line with this information, in the study; sound absorption coefficient measurements were made with the impedance tube method of scotch pine and eastern beech trees, which are natural wood materials that have a high usage area in interior architecture.

Acoustic properties of wood material

Covering materials, which are made of natural wood materials, have regulating, absorption and anti-reflection effects on sound waves. Undesirable sounds are generated by echoing sound waves on walls with smooth surfaces and no elements. Opening windows or windows can prevent such unwanted sounds. In addition, it can be solved by covering the walls with sound absorbing materials (fabric, felt, wood and wood-based materials, etc.). To regulate the sound waves in the air, to ensure that the sound spreads properly and to obtain sufficient sound

absorption, in social areas wood-based materials should be used in the interior wall and ceiling coverings (Berkel 1970).

The speed of sound propagation decreases as the moisture in the wood increases and its structure becomes irregular by separating from its uniformity. The most important feature of wood material is that despite its low weight, the speed of sound propagation is high. Sound propagation rates of some tree species are given in Table 1 (Berkel 1970).

Table 1: Propagation sound waves through some tree species (Berkel 1970).

Tree Type	Propagation Velocity c // (m/s)
Scotch Pine	4760
Eastern beech	4638

Sound

In a flexible environment, the vibration caused by small fluctuations or changes that people can hear is called sound. In order for the fluctuations occurring around the equilibrium pressure in a certain environment to be considered as sound, they must have certain conditions. It was reported that the sound requires a source point and a flexible medium in which the impact waves will propagate (Çalışkan 2004).

Sound absorption coefficient

The sound absorption coefficient (α) is defined as the ratio of the energy of the sound passing on the other side of the obstacle to the energy of the sound on the front face of the wall. Considering the building materials used in practice, the value of this coefficient is very small and is between 0,0001 and 1 (Çalışkan 2004). The sound absorption coefficient of a surface varies depending on the property of the material (whether it is porous), its thickness and frequency of sound (Özgüven 2008).

Acoustics and noise

Every person has different approaches to noise. While most people have normal attitudes towards noise, 5 % are insensitive and the rest are very sensitive to it. Workers in long-term working environments where the noise level is above 80 dB are likely to experience permanent hearing impairment in later life (Babalık 2003).

Prolonged exposure to loud noise, around 100 dB, can lead to permanent hearing loss. Noise can have other effects on the human body such as changes in breathing and heart rate, increase in blood pressure and deterioration in the digestive system. Too much noise can make people feel nervous. Along with discomforts such as fatigue and headache, it can also lead to anorexia, s (Ersoy 2001).

Materials and methods

In this study, scotch pine (*Pinus sylvestris* L.) and eastern beech (*Fagus orientalis* L.) trees, which are natural wood materials and have an important usage area in interior decoration, were used as experimental material. Superficial and radial sections of wood samples were used. Wood samples were chosen by considering the extensive usage of these wood materials in interior decoration, market conditions and their different patterns. Considering that the use of natural wood material in its raw form do not match with reality, it was thought that it should be used as coated form. Wood samples were coated with water-based varnishes that do not contain solvent-based substances and do not pose a risk to health. The surfaces of the tangential and radial sections obtained for this purpose were determined as test material and samples were coated with single and double component water-based varnishes.

Scots pine (*Pinus sylvestris* L.) its sapwood is broad annual rings distinct and slightly wavy. Its color is red, it is easy to process, its inner wood ratio is high. It is very resinous. Its specific gravity is 0,49 g/cm³ (Gürtekin and Oğuz 2002). It is a softwood tree species with bright, dense and wide resin channels in radial and superficial sections. It is used in furniture and turnery, especially as building material (doors, windows, paneling, floor and ceiling coverings) (Örs and Keskin 2001).

Eastern beech (*Fagus orientalis* L.) it is a group of mature woody trees. The wood is reddish-white in natural condition and brick-red in kiln-dried condition. Annual rings are prominent. It has a color close to pink (Gürtekin and Oğuz 2002). It is a medium hard wood that can be processed easily. It is suitable for bending. It is not durable in humid environments. For this reason, it is mostly used indoors. Its specific gravity is 0,63 g/cm³. It is used in furniture, parquet, veneer, plywood, and turnery. It is also used in the production of packaging, toys, agricultural tools, railway sleepers, barrels, and kitchen tools (Örs and Keskin 2001).

Water-based varnishes

Until the last quarter of the 20th century, most of the paint/varnish consumption in the world was soluble in organic solvents. Meanwhile, according to the clean air treaty signed in the USA; In paint/varnish applications, the importance of water-solvent paint/varnish has gradually increased with the limitation of the use of volatile organic compounds released into the atmosphere and keeping the values of them low in the following years (Sönmez and Budakçı 2004). Water-based varnishes are mixtures produced by combining many different types of resins. Varnishes, which have started to be used extensively in the industry, are prepared based on polymerization (Johnson 1997).

In thermoset structure, there is no molecular transformation in the layers. In this structure, molecules form a large molecule by cross-linking with first-order cross-links. In thermoplastic structure, the arrangement of molecules is linear (linear) and II are held together by forces of I.

order. In the thermoset structure, the polymerization is completed by a reaction initiator or the effect of high temperature and is not affected by the temperature after the layer has hardened. In thermoplastic structure, the hardened layer softens with the effect of heat, and when the effect of heat is removed from the environment, it reaches its old hardness again. The shape, arrangement, and polarity of the molecules in both thermoplastic and thermoset structures affect the physical properties of the polymer. The cross-links formed by first-order forces in the thermoset structure are direct chemical bonds and do not deteriorate with heat, water, solvent, and mechanical stresses. As the number of crosslinks increases, the hardness and stiffness increase. In this manner when the degree of crosslinking decrease, the flexibility of the layer is increase (Sönmez *et al.* 2004).

The wood material used in the preparation of the test samples was obtained by random means from companies in Ankara and Konya. The samples were prepared from the sapwood parts according to the principles specified in ASTM-D 358 (1983) and TS 2470 (1976), from first class wood material, with smooth fibers, no knots, no cracks, no tulle formation and no growth defects, no color and density difference, not reacted with any chemicals, not damaged by fungi and insects, annual rings perpendicular to the surfaces. Dry samples were cut as drafts in the size of 110 mm x110 mm x 22 mm. The samples were kept in an air-conditioning cabinet at a temperature of 20 °C and a relative humidity of 60 ±5 % according to ASTM D3924 (1991) and TS2471 (1976) until they reached constant weight. Then it was measured as ø100 and ø29 mm Figure 1 and Figure 2 with 18 mm thickness and 3 test samples were prepared for each type of material.

In the experiments, one-component primary resin (S) (produced by Johnson firm) and acrylic modified polyurethane copolymer resin (D) (produced by Kimetsan) were used as two-component varnish topcoat.

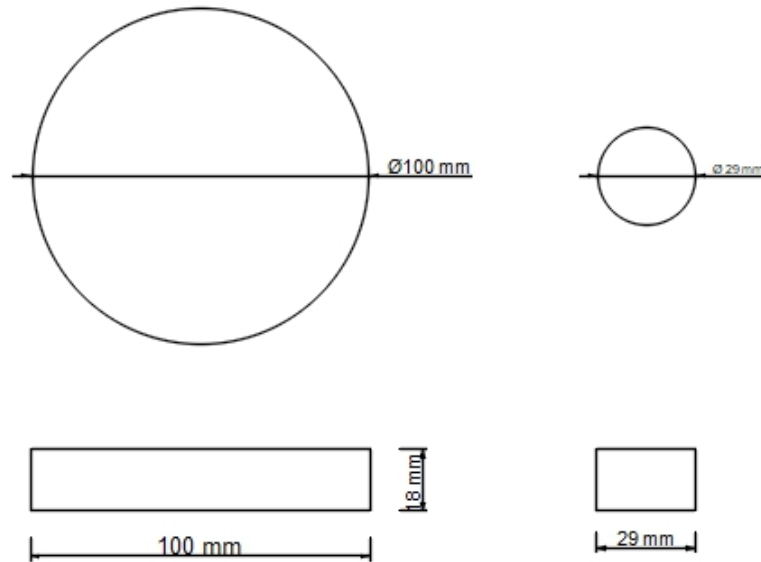

Figure 1: Cutting dimensions of the test samples.

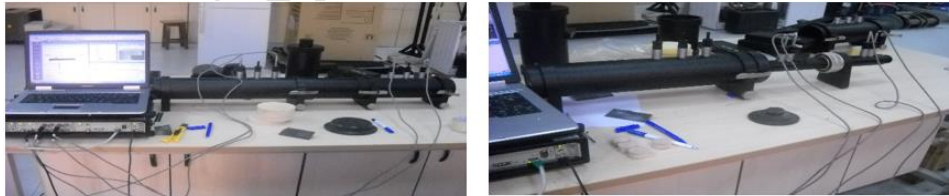

Figure 2: Experimental setup pictures.

In the varnishing process, the trial material varnishes were applied according to the principles and industrial applications specified in ASTM D3023 (1998). In making the varnishes ready for the application, the mixing ratios of hardener and water were made in a way that would not adversely affect the layer performance and in line with the recommendations of the manufacturers. 2 coats of filler and 2 coats of topcoat varnish were applied. During the varnishing of the samples with double component varnish, the tip opening of gun and air

pressure were adjusted in accordance with the manufacturer's recommendations. The varnish gun was moved horizontally and at a height of 20 cm from the sample surface.

The fiber swellings on the sample surfaces, on which filler layers were applied, were removed with sandpaper no. 300. In the application of water solvent varnish amounts, the amount of solid matter is considered and two coats of varnish were applied, with an average of 70 g/m² per coat. It is applied in a varnish laboratory equipped with a two-component water-solvent varnish solution, using a varnish spray gun with a 0,7 mm tip opening specially produced for water-solvent varnishes and paints. One-component water-solvent primary resin was applied with a soft-bristled varnish brush as filler + topcoat, as problems were encountered in the application with a varnish spray gun.

Method

Experimental set-up used in our experiments is seen in Figure 3 and Figure 4. Impedance tube was used for the measurements and sound absorption coefficients were determined with the international standard ISO10534-2 (2004). The measurements were carried out in a laboratory environment with an ambient temperature of 23 °C and a humidity of 50 % in the frequency range of 50 Hz - 6400 Hz.

Applications for Type 4206-T



Type 4206-T Large tube set up



Type 4206-T Small tube set up

Figure 3: Measurement system of sound absorption coefficient depending on frequency (Bruel Kjaer 2024).

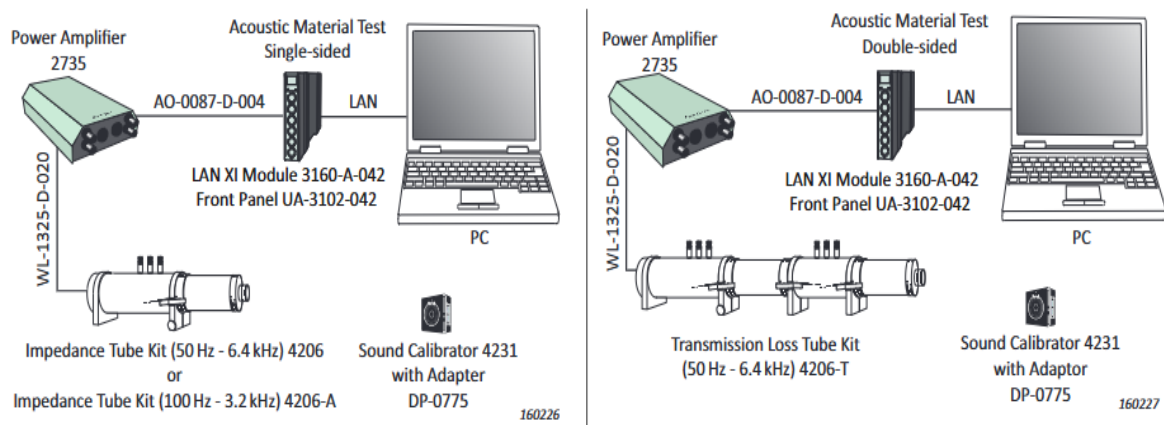

Figure 4: The physical layer of the analyzed system (Brüel and Kjaer 2024).

Evaluation of data

After the sound absorption coefficients of the samples used in the experiments were determined using the impedance tube method, they were evaluated by taking their average values according to the 1/13 octave band. For investigating the change in sound absorption coefficient with respect to the type of wood material, intersection direction and varnish type several experiments were carried out. The obtained sound absorption coefficient values are given in the findings

section together with the results of the pairwise comparison (tangential section, radial section, single component varnish, double component varnish) and the results of the triple comparison of the Wood type-Incision direction-Varnish type.

Results and discussion

Results

Intensity

Some statistical data on the density of of air dried (MC) wood material types used in the experiments are given in Table 2.

Table 2: Arithmetic averages of air-dry densities.

Tree type	N	Air dry density (kg/m ³)	Standard deviation	Variance	X _{min.}	X _{max.}
Scotch pine	10	510	0,03	0,0010701	0,48	0,59
Eastern beech	10	620	0,01	0,0000313	0,61	0,62

According to the results, there are differences between the air-dry density values of wood material types. The density was found as 510 kg/m³ for scotch pine tree and 620 kg/m³ for beech tree.

After measuring the samples with the impedance tube method between the frequency value of 50 Hz - 6400 Hz, the sound absorption coefficient results were analyzed according to the 1/13 octave band and the tables were created based on the values that are significant in the 160 Hz - 4000 Hz range.

Comparison results of wood material type

According to these test results, while the sound absorption coefficient gave close results in the frequency range of 500 Hz - 1000 Hz, the highest sound absorption coefficient was obtained at 5000 Hz frequency value, $\alpha=0,169$, in the control sample of the superficial cross section of the scotch pine tree. The obtained results are given in Figure 5.

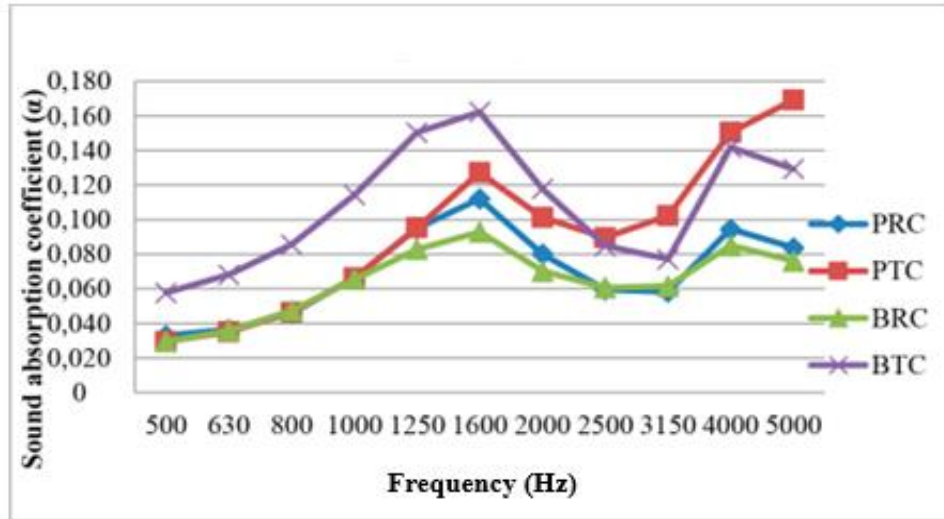

Figure 5: Comparison of control samples of wood material type.

(PRC: Pine-Radial-Control, ÇTK: Pine-Targent-Control BRC: Beech-Radial-Control, BTC: Beech-Targent-Control)

Comparisons of radial intersect direction

In the experimental results of the radial intersection direction, while the sound absorption coefficient values were found close to each other in the frequency range of 500-1000 Hz, the highest sound absorption coefficient value was obtained in the radial section of the Scots Pine Tree with $\alpha=0,284$. The comparison results of the sound absorption coefficient values of the Radial Section direction of wood material types are given in Figure 6.

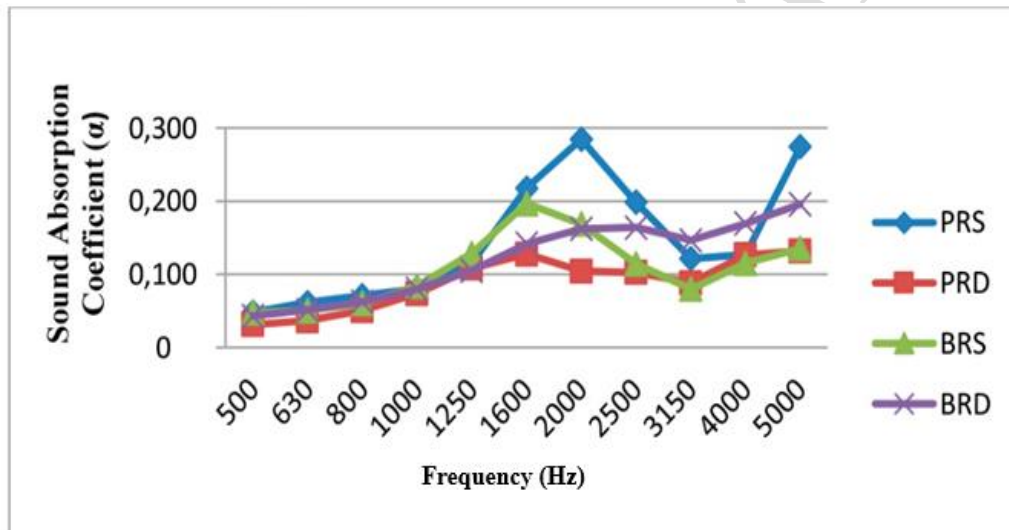

Figure 6: Comparison of the samples of the radial cutting direction.
(PRS: Pine-Radial-Single Comp., PRD: Pine-Radial-Double Comp. BRS: Beech-Radial-Single Comp., BRD: Beech-Radial-Double Comp)

Tangent cutting direction comparisons

In the experimental results of the superficial intersection direction, while the sound absorption coefficient values were found close to each other in the frequency range of 630 Hz - 1000 Hz,

the highest sound absorption coefficient value was obtained in the tangent section of the eastern beech tree with $\alpha=0,391$. The obtained results are given in Figure 7.

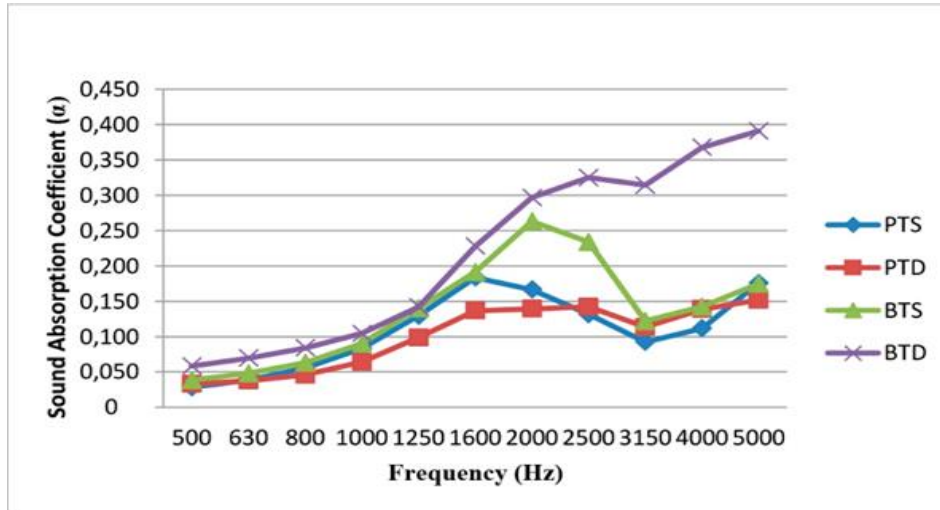

Figure 7: Comparison of the samples of the tangent cutting direction.
(PTS: Pine-Targett-Single Comp., PTD: Pine- Targett -Double Comp BTS: Beech- Targett -Single Comp.,
BTD: Beech- Targett -Double Comp.)

Comparisons of single component varnish type

In the experimental results of the single component varnish type, the sound absorption coefficient values were found close to each other in the 500 Hz - 1000 Hz frequency range, while the highest sound absorption coefficient value was obtained in the radial section of the pine tree with $\alpha=0,284$ at the 2000 Hz frequency value. The obtained results are given in Figure 8.

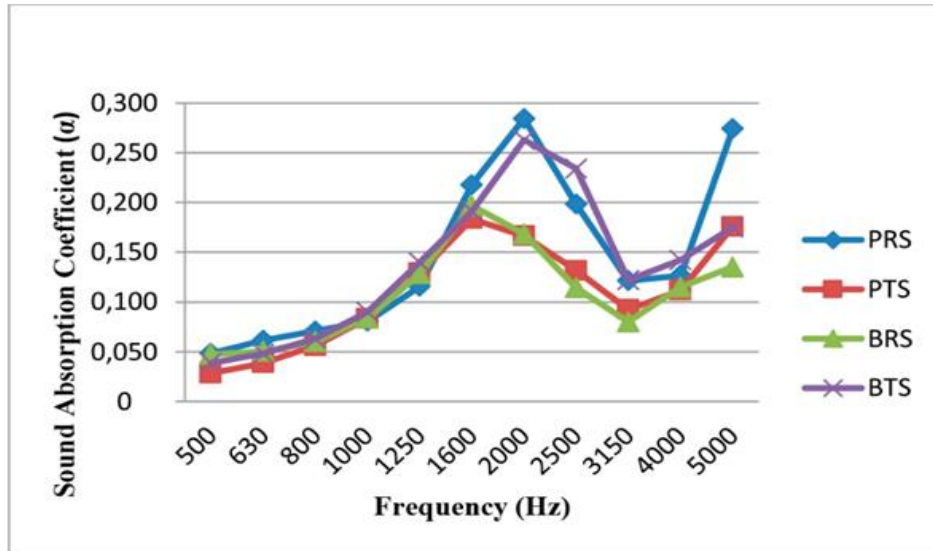

Figure 8: Comparison of samples of one component varnish.
(PRS: Pine-Radial-Single Comp. PTS: Pine-Tangent-Single Comp. BRS: Beech-Radial-Single Comp. BTS: Beech-Tangent-Single Komp.)

Comparisons of double component varnish type

In the experimental results of the double component varnish type, while the sound absorption coefficient values were found close to each other in the frequency range of 500 Hz - 1000 Hz, the highest sound absorption coefficient value was obtained in the Tangent section of the beech tree with $\alpha=0,391$ at the frequency of 5000 Hz. The obtained results are given in Figure 9.

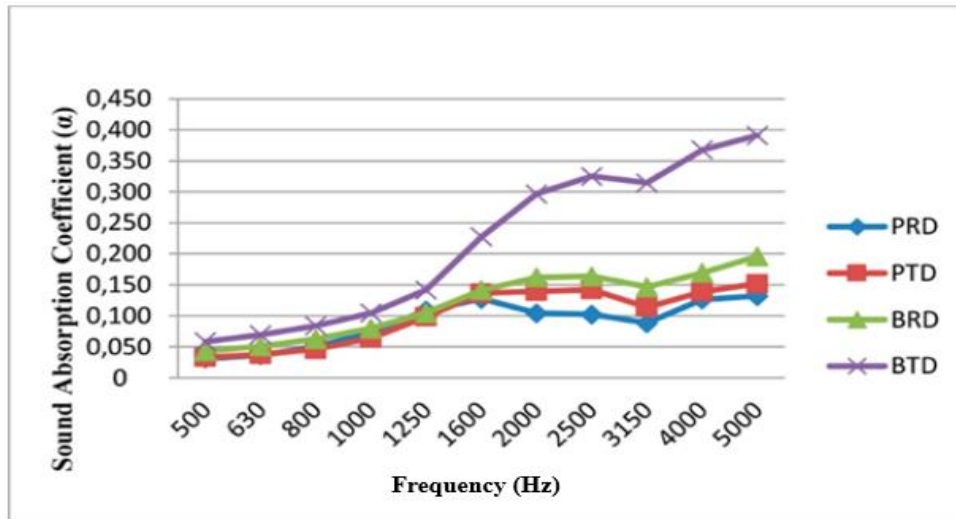

Figure 9: Comparison of samples of double component varnish.
 (PRD: Pine-Radial-Double Comp. PTD: Pine-Target- Double Comp. BRD: Beech-Radial- Double Comp.
 BTD: Beech-Target- Double Comp.)

Wood type-cutting direction-comparison of varnish type

In the experimental results of the triple comparisons, the sound absorption coefficient values were obtained between $\alpha=0,03 - 0,1$ in the frequency range of 500 Hz - 1000 Hz, while the highest sound absorption coefficient value was obtained with $\alpha=0,391$ in the superficial cross-section double component varnished sample belonging to the eastern beech tree. The obtained results are given in Figure 10.

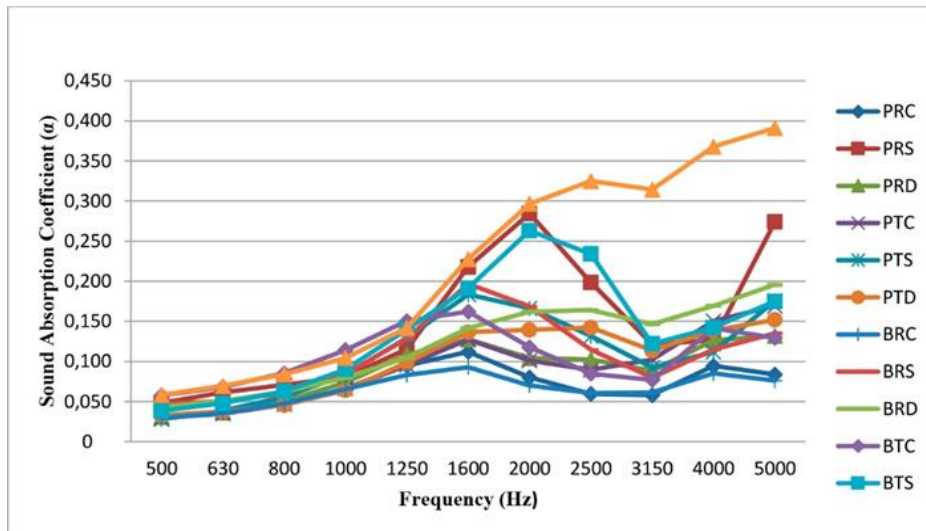

Figure 10: Wood type-cutting direction-varnish type comparison.

(PRC: Pine-Radial-Control, PRS: Pine-Radial-Single Comp., PRD: Pine-Radial-Double Comp.

PTC: Pine-Tangent-Control, PTS: Pine-Tangent- Single Comp, PTD: Pine-Tangent- Double Comp

BRC: Beech- Radial-Control, BRS: Beech- Radial -Single Comp., BRD: Beech- Radial -Double Comp

BTC: Beech- Tangent-Control, BTS: Beech- Tangent - Single Comp, BTD: Beech- Tangent - Double Comp)

Discussion

In the control samples, the highest sound absorption coefficient value was obtained in the superficial cross-section sample ($\alpha=0,169$) of the scotch pine tree. It was thought that the amount of inorganic materials in the intercellular passages in wood material and the differences in the amount of extractive organic material in the wood material (especially scotch pine) may be effective in the loss of sound transmission (Berkel 1970). The cell arrangement differences in the superficial section had an increasing effect on the sound absorption coefficient.

When the comparisons of the radial cross-sections of wood materials were made, the highest sound absorption coefficient value was obtained with $\alpha=0,284$ in the radial section of the scots pine tree. It can be thought that the extractive substances contained in the scotch pine tree were effective in the sound absorption coefficient values at low frequencies.

In the comparison of the test samples with superficial section, the highest sound absorption coefficient value was obtained in the tangent section of the eastern beech tree with $\alpha=0,391$ at 5000 Hz frequency. As stated in the literature, the specific gravity, surface roughness and frequency of the wood material increase in direct proportion to the sound absorption coefficient (Berkel 1970). It was thought that of being specific gravity of the oriental beech tree was higher than that of the scotch pine tree, resulted in increase of the sound absorption coefficient.

In the experimental results of the single component varnish type, the highest sound absorption coefficient value was obtained in the radial section of the scotch pine tree with a frequency value of $\alpha=0,284$ at 2000 Hz. It could be thought that the extractive substances in the scotch pine tree had a positive effect on the loss of sound transmission. In addition, it could be said that the single component in thermoplastic structure with smaller molecules and linear array was not very effective for this situation, and the materials in the wood materials affected the sound absorption coefficient.

In the experimental results of the double component varnish type, the highest sound absorption coefficient value was obtained in the tangential section of the beech tree with $\alpha=0,391$ at 5000 Hz frequency. It has been determined that the sound transmission loss was high in the double component varnish layers, which were two component water-based varnish with thermoset properties in branched polymeric structure with large molecular structure. In these results, it was thought that the thermoset structure of the two-component varnish in water-based varnish systems affected the sound transmission loss positively.

According to the wood material type-cutting direction-varnish type comparison results, the highest sound absorption coefficient value, $\alpha=0,391$, was obtained in the superficial cross-section double-component varnished sample belonging to the eastern beech tree. In addition to

the specific gravity of the wood material, the porous structure of the material and the cell arrangement according to the sections and the number of conduction tissues and the size of the intercellular space volume were thought to be effective in the sound transmission loss. In radial section, annual rings, spring and summer wood, sapwood and heartwood, inner bark and outer bark are in the form of longitudinal strips, resin canals and tracheas are in the form of longitudinal fine scratches. On the radial section, although the core rays vary according to the tree species, they take place in the form of bright platelets. It could be said that the difference in summer wood participation rates in superficial and radial sections, and the cell arrangement differences in tangential and radial sections were effective in sound transmission loss of wood materials.

Conclusions

The sound absorption coefficient of solid wood materials, which have an important area of use in interior design, was determined by the impedance tube method. When using natural wood materials, cutting directions in superficial and radial directions were considered, and the effect of the cut direction on the sound absorption coefficient was determined. It was observed that the superficial section had a better sound absorption coefficient value than the radial section. In addition, by examining the effect of single and double component varnishes, which are solvent-free water-based varnish systems, it was thought that double-component varnishes had a positive effect on the sound absorption coefficient.

As a result, the primary purpose of choosing wood-based wall coverings, which are generally used as interior decoration materials, in places such as cinemas, theaters and concert halls, are absorbing the sounds in the space, to ensure the proper spread of the sounds in the space, and meet the aesthetic needs. In the production of wood-based wall coverings or partition elements, stemless beech wood should be preferred primarily, the use of superficial cross-section material should be considered when considering the decorative and taste factor, and the use of solvent-free and healthy double-component water-based varnish should be preferred in the choice of varnish.

Authorship cobtributions

M.S.M.: Conceptualisation, data curation, formal analysis, investigation, methodology, project management, resources, software, verification, visualization, writing – original draft, writing – review and editing.

References:

- Akdağ, N. 1999.** Measures Required for Sound Pass Loss and Noise Control in Doors. Istanbul University Publication. Turkish Chamber of Mechanical Engineers Insulation Congress. 11-12 February. Publication 213. pp. 53-64, Istanbul, Turkey.
- Akdağ, N.Y. 2001.** Evaluation of Interior Walls in terms of Sound Insulation. In: Turkish Chamber of Mechanical Engineers Chamber of Mechanical Engineers Insulation Congress. 23-25 March. pp. 108-114. Istanbul, Turkey
- ASTM. 1983.** Wood to be Used as Panels in Weathering Tests of Coatings. ASTM D358. 1983. American Society for Testing and Materials, pp. 1-3.
- ASTM. 1991.** Standart Specification for Standard Environment for Conditioning and Testing Point Varnish Lacquer and Related Materials. ASTM D3924. 1991. American Society for Testing and Materials, pp. 1-3.
- ASTM. 1998.** Standart Practice for Determination of Resistance of Factory Applied Coatings on Wood Products of Stain and Reagents. ASTM D3023. 1998. American Society for Testing and Materials: USA.
- Ayan, S. 2012.** Determination of acoustical properties of heat treated laminated wooden panels. PhD Thesis. Gazi University. 179p.
- Babalık, F. 2003.** Noise at work and the possibility of deafness. In. Proceedings of II. Occupational Health and Safety Congress/ISG-01. Adana, Turkey. 2-3 May 2003.

- Berkel, A. 1970.** Wood Material Technology. Istanbul University Faculty of Forestry Publications. Istanbul University Publication Number 1448. Istanbul, Turkey.
- Bruel Kjaer. 2024.** Bruel Kjaer Transmission Loss Tube Kit (50Hz - 6.4 kHz) - Type 4206. <https://www.bksv.com/media/doc/bp1039.pdf>
- Belgin E.; Çalışkan M. 2004.** Protection of Noise and Hearing in Working Life. Turkish Medical Association Publications. Ankara, Turkey. pp.17-44. ISBN 975-6984-65-1 https://www.ttb.org.tr/kutuphane/isak_gurultu_kitap.pdf
- Chung, H., Park, Y., Yang, SY.; Kim, H.; Han, Y.; Chang, Y.; Yeo, H. 2017.** Effect of heat treatment temperature and time on sound absorption coefficient of Larix kaempferi wood. *Journal Wood Science* 63: 575–579. <https://doi.org/10.1007/s10086-017-1662-z>
- Choe, H.; Sung, G.; Kim, J.H. 2018.** Chemical treatment of wood fibers to enhance the sound absorption coefficient of flexible polyurethane composite foams. *Composites Science and Technology* 156: 19-27. <https://doi.org/10.1016/j.compscitech.2017.12.024>.
- Ersoy, S. 2001.** Investigation of Sound Absorption Properties of Industrial Tea-Lubber-Fiber Wastes. Master Thesis. Marmara University. 55p.
- Gürtekin, A.; Oğuz, M. 2002.** Furniture and Decoration Material Knowledge. National Education Press: Istanbul, Turkey. pp. 15-16. ISBN 975-11-221-7.
- Kolya, H.; Chun-Won, K. 2021.** Hygrothermal treated paulownia hardwood reveals enhanced sound absorption coefficient: An effective and facile approach. *Applied Acoustics* 174. e107758. <https://doi.org/10.1016/j.apacoust.2020.107758>
- ISO.2004.** Acoustics Determination of Sound Absorption coefficient And Impedance or Admittance By The Impedance Tube Method. ISO/DIS10534. 2004. International Standard Organization: Switzerland.
- Johnson, R. (1997).** Waterborne coatings-An overview of waterborne coatings: A formulator's perspective. *Journal of Coatings Technology* 69(864): 117-121.
- Kaya, A. İ.; Dalgat, T. 2017.** Acoustic Properties of Natural Fibers in Terms of Sound Insulation. *Journal of Mehmet Akif Ersoy University Institute of Science and Technology* 8(Special 1): 25-37. <http://dergipark.ulakbim.gov.tr/makufebed>
- Keskin, O.; Yılmaz, S. 2020.** Parameters Affecting Sound Absorption Performance in Gourd Fiber (*Luffa Cylindrica*)-Epoxy Composite. *Süleyman Demirel University, Journal of Natural and Applied Sciences* 24(1): 201-208. <https://doi.org/10.19113/sdufenbed.681607>
- Kayılı, M. 1981.** Increasing the Sound Transmission Loss of Lightweight Partition Elements with the Addition of Helmholtz Resonators. PhD thesis. Istanbul Technical University Faculty of Architecture. 98p.
- Örs, Y.; Keskin, H. 2001.** *Wood Material Knowledge*. Publication 2. pp. 159-163. ISBN 975-6574-01-1
- Özgülven, N. 2008.** Noise Control- Industrial and Environmental Noise. Turkish Acoustic Association Technical Publications. 2nd Edition. 124p. ISBN:978-605-89991-0-7. <https://takder.org/?p=1979>.
- Özkan, S. 2001.** Sound Insulation Applications. In. Turkish Chamber of Mechanical Engineers Insulation Congress. 23-25 March. pp. 114-120. Eskişehir, Turkey Publication Number: E/2001/264. https://www.mmo.org.tr/books/insulation_2001_congress_and_exhibition_proceedings_book.
- Sönmez, A.; Budakçı, M. 2004.** Top Surface Treatments in Woodworking II, Protective Layer and Paint / Varnish Systems. Gazi University Faculty of Technical Education.: Ankara, Turkey p. 34-48. ISBN: 975-97281-0-9 (TK), 975-97281-1-7 (2.C.)
- Sönmez, A.; Budakçı M.; Yakın, M. 2004.** The Effects of Water Solvent Varnish Applications on Wood Material on Hardness, Gloss and Adhesion Resistance. *Gazi University*

Journal of Polytechnic 7(3): 229-235. Ankara, Turkey.

<https://dergipark.org.tr/en/pub/politeknik/issue/33010/366972>

TS ISO 3129. Wood - Sampling methods and general requirements for physical and mechanical testing of small clear wood specimens. Turkish Standardization Institute: Ankara, Turkey.

TS (1976) 2471. Determination of Moisture Amount for Physical and Mechanical Experiments in Wood. TS 2471. 1976. Turkish Standardization Institute: Ankara, Turkey. pp. 1-2.

Tudor, E.M.; Dettendorfer, A.; Kain, G.; Barbu, M.C.; Reh, R.; Krišťák, Ľ. 2020.

Sound-Absorption Coefficient of Bark-Based Insulation Panels. *Polymers* 12(5). e1012.

<https://doi.org/10.3390/polym12051012>

Wassilieff, C. 1996. Sound Absorption of Wood-Based Materials. *Applied Acoustics* 48 (4):

339-356 [https://doi.org/10.1016/0003-682X\(96\)00013-8](https://doi.org/10.1016/0003-682X(96)00013-8)

Yang, H.S.; Kim, D.J.; Kim, H.J. 2003. Rice Straw-Wood Particle Composite for Sound Absorbing Wooden Construction Materials. *Bioresource Technology* 86: 117-121.

[https://doi.org/10.1016/S0960-8524\(02\)00163-3](https://doi.org/10.1016/S0960-8524(02)00163-3)

ACCEPTED PAPER